

8404  
1:48

# Bf 110G-4

eduard  
WEEKEND

**PLASTIC PARTS EDITION**

**C>** **G>** **J>** **N>**

**T>** **F>** **R>** **S>**

**U>** **V>** **W>**

Mr.COLOR	
C3	RED
C4	YELLOW
C5	BLUE
C7	BROWN
C18	RLM 70
C33	FLAT BLACK
C37	RLM 75
C41	RED BROWN
C43	WOOD BROWN
C60	RLM 02
C62	WHITE
C81	RUSSET
C116	RLM 66
C123	RLM 83
C117	RLM 76
C123	RLM 83
C137	TYRE BLACK
Mr. METAL COLOR	
MC214	DARK IRON
MC218	ALUMINIUM
MC219	BRASS

**ATTENTION \* UPOZORNĚNÍ \* ACHTUNG \* ATTENTION**

- (GB)** Carefully read instruction sheet before assembling. When you use glue or paint, do not use near open flame and use in well ventilated room. Keep out of reach of small children. Children must not be allowed to suck any part, or pull vinyl bag over the head.
- (CZ)** Před začátkem stavby si pečlivě prostudujte stavební návod. Při používání barev a lepidel pracujte v dobře větrané místnosti. Lepidla ani barvy nepoužívejte v blízkosti otevřeného ohně. Model není určen malým dětem, mohlo by dojít k požití drobných dílů.
- (D)** Von dem Zusammensetzen die Bauanleitung gut durchlesen. Kleber und Farbe nicht nahe von offenem Feuer verwenden und das Fenster von Zeit zu Zeit Belüftung öffnen. Bausatz von kleinen Kindern fernhalten. Verhüten Sie, daß Kinder irgendwelche Bauteile in den Mund nehmen oder Plastiktüten über den Kopf ziehen.
- (F)** lire soigneusement la fiche d' instructions avant d' assembler. Ne pas utiliser de colle ou de peinture à proximité d' une flamme nue, et aérer la pièce de temps en temps. Garder hors de portée des enfants en bas âge. Ne pas laisser les enfants mettre en bouche ou sucer les pièces, ou passer un sachet vinyl sur la tête.

**INSTRUCTION SIGNS \* INSTR. SYMBOLY \* INSTRUKTION SINNBILDEN \* SYMBOLES**

- (?)** OPTIONAL  
FACULTATIV  
NACH BELIEBEN  
VOLBA
- (f)** BEND  
PLIER SIL VOUS PLAIT  
BITTE BIEGEN  
OHNOUT
- (M)** OPEN HOLE  
FAIRE UN TROU  
ÖFFNEN  
VYVRTAT OTVOR
- (S)** SYMMETRICAL ASSEMBLY  
MONTAGE SYMÉTRIQUE  
SYMMETRISCHE AUFBAU  
SYMETRICKÁ MONTÁŽ
- (N)** NOTCH  
L INCISION  
DER EINSCHNITT  
ZÁREZ
- (X)** REMOVE  
RETIRER  
ENTFERNEN  
ODRŮZNOUT

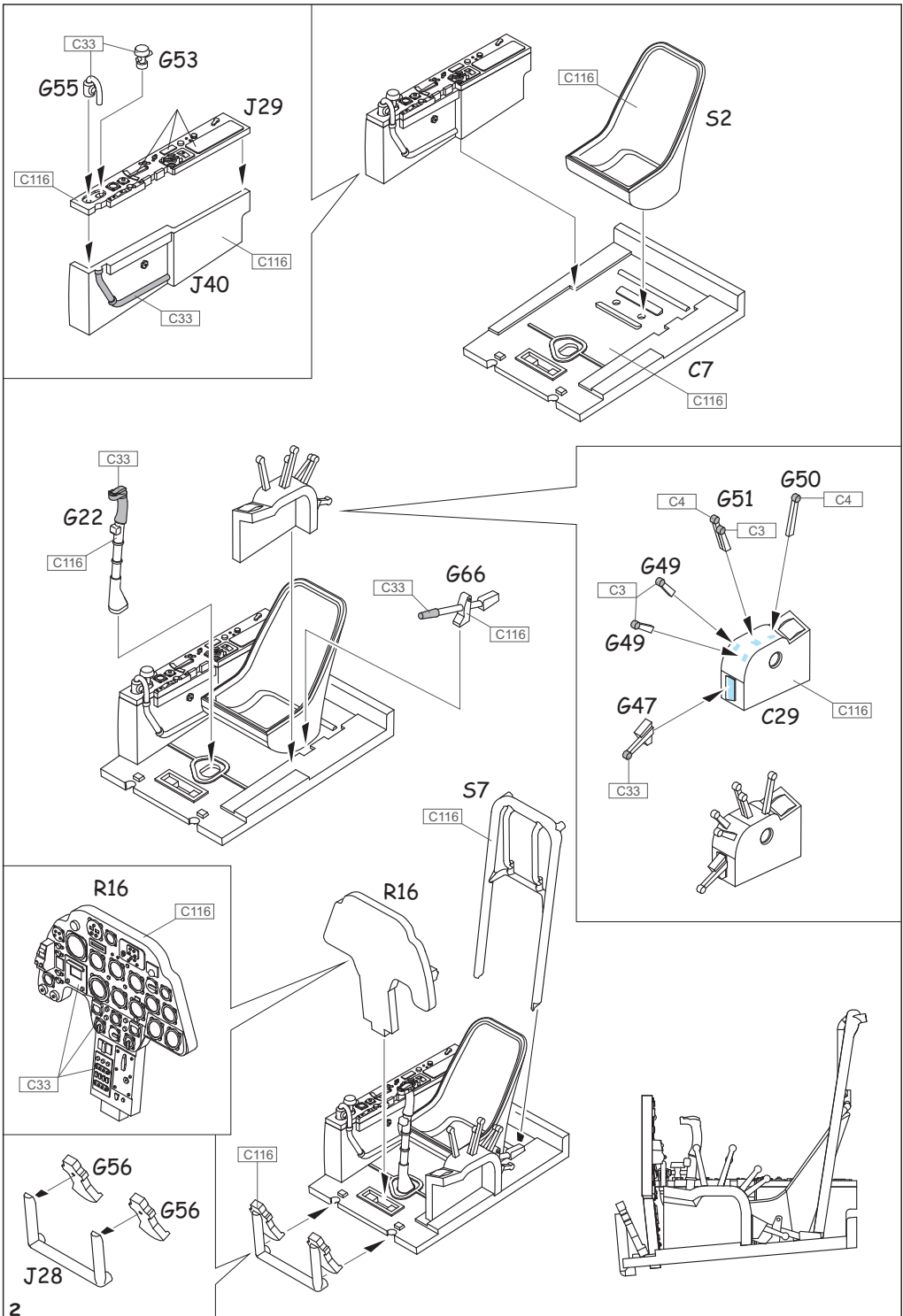

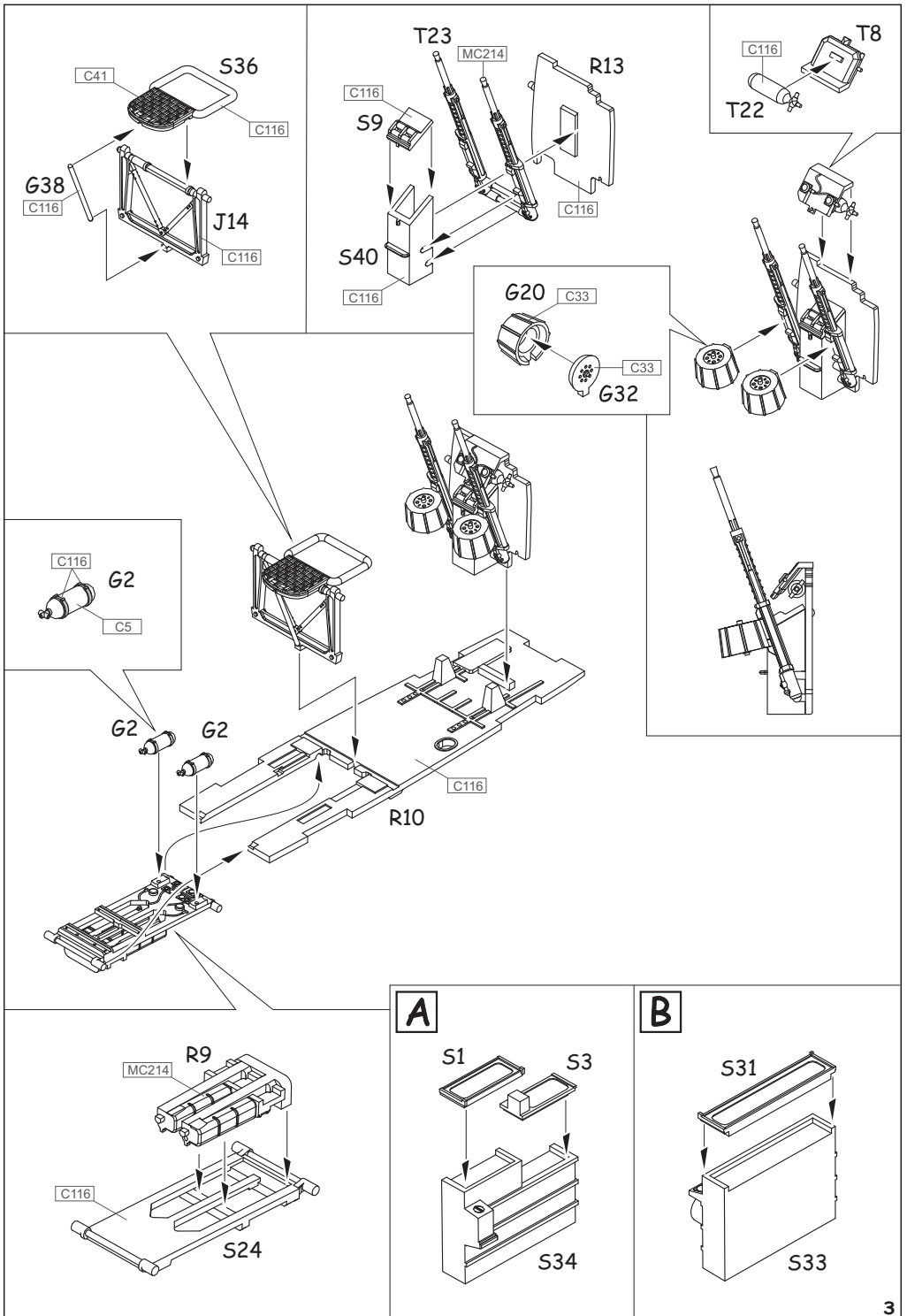

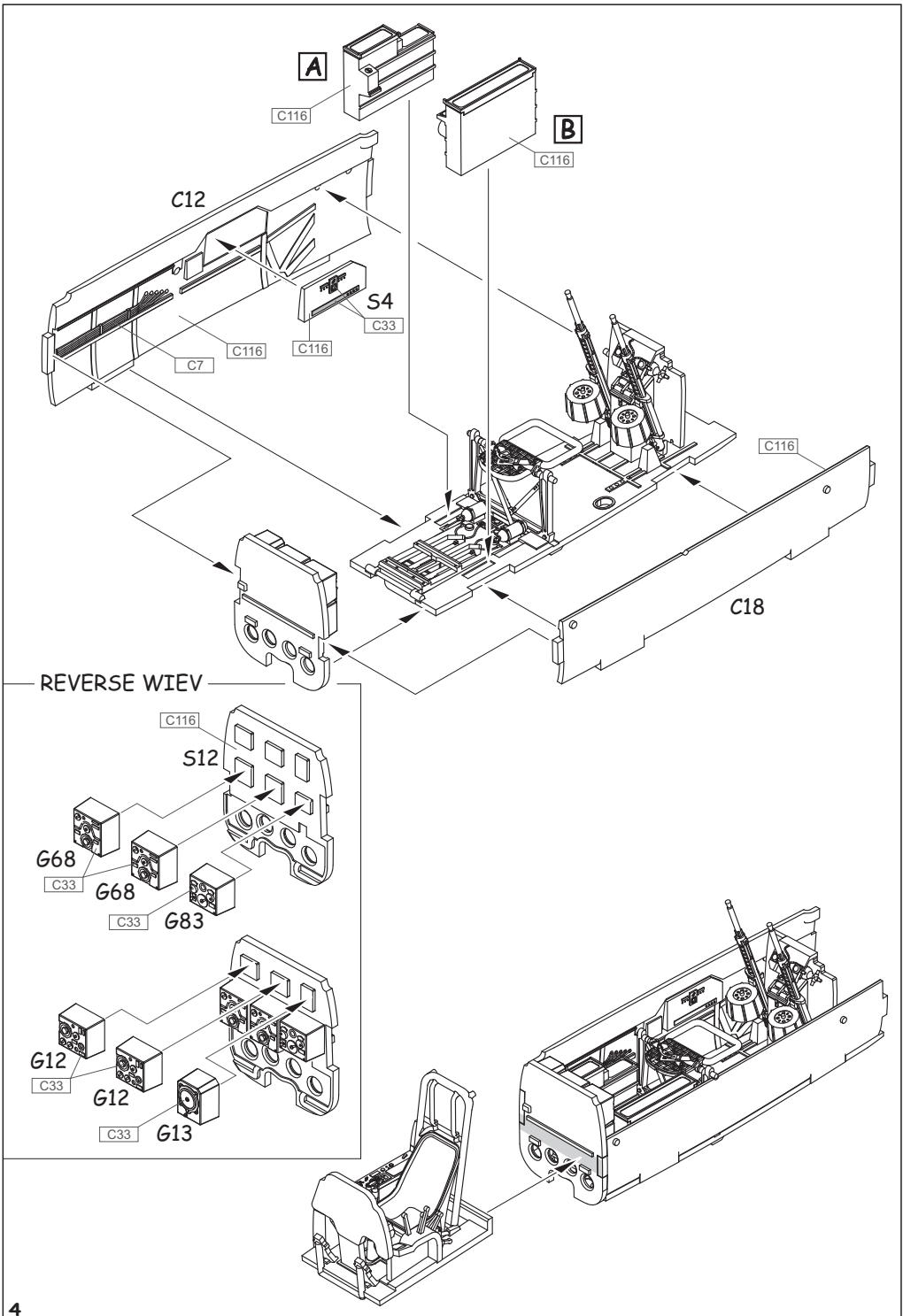

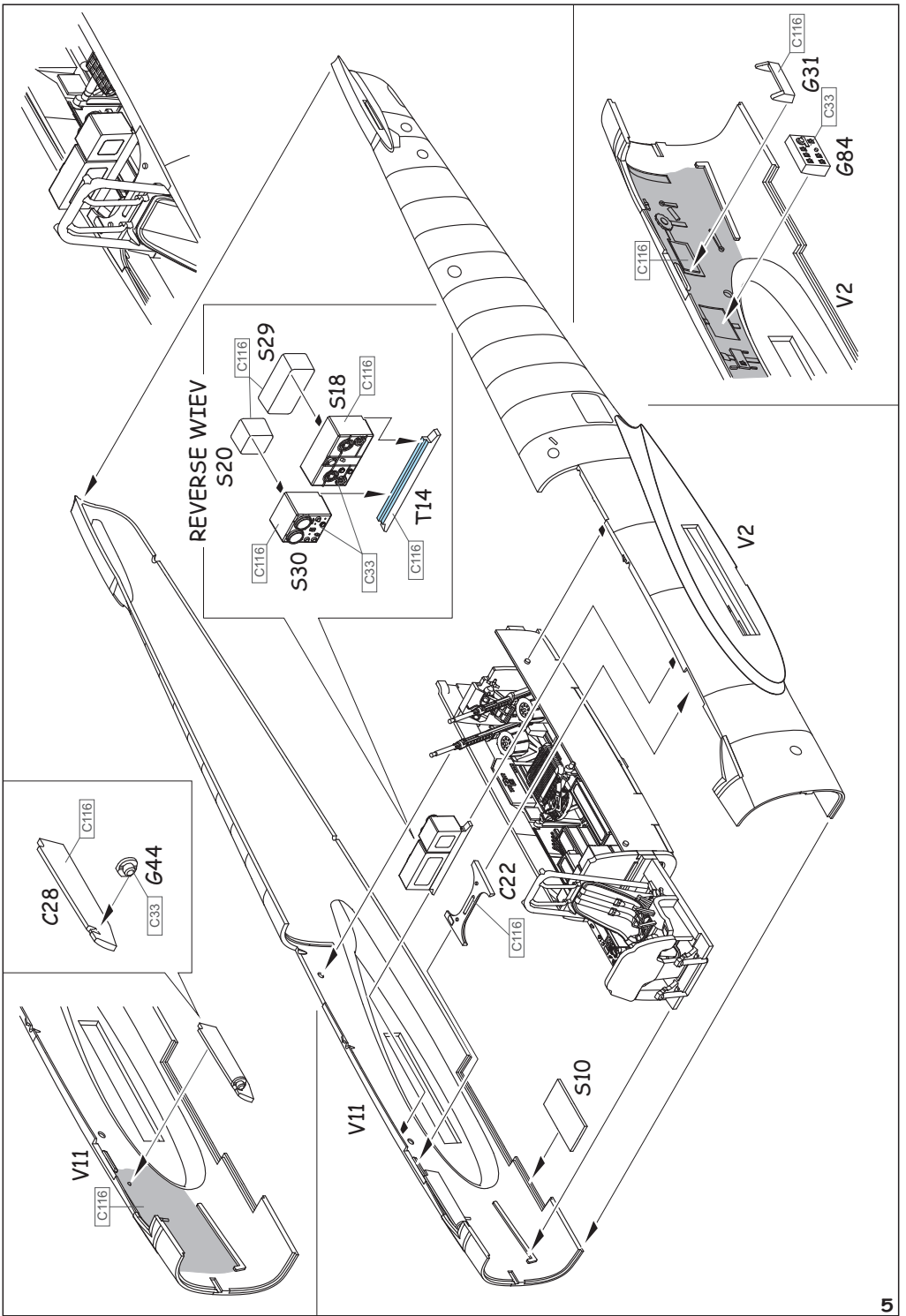

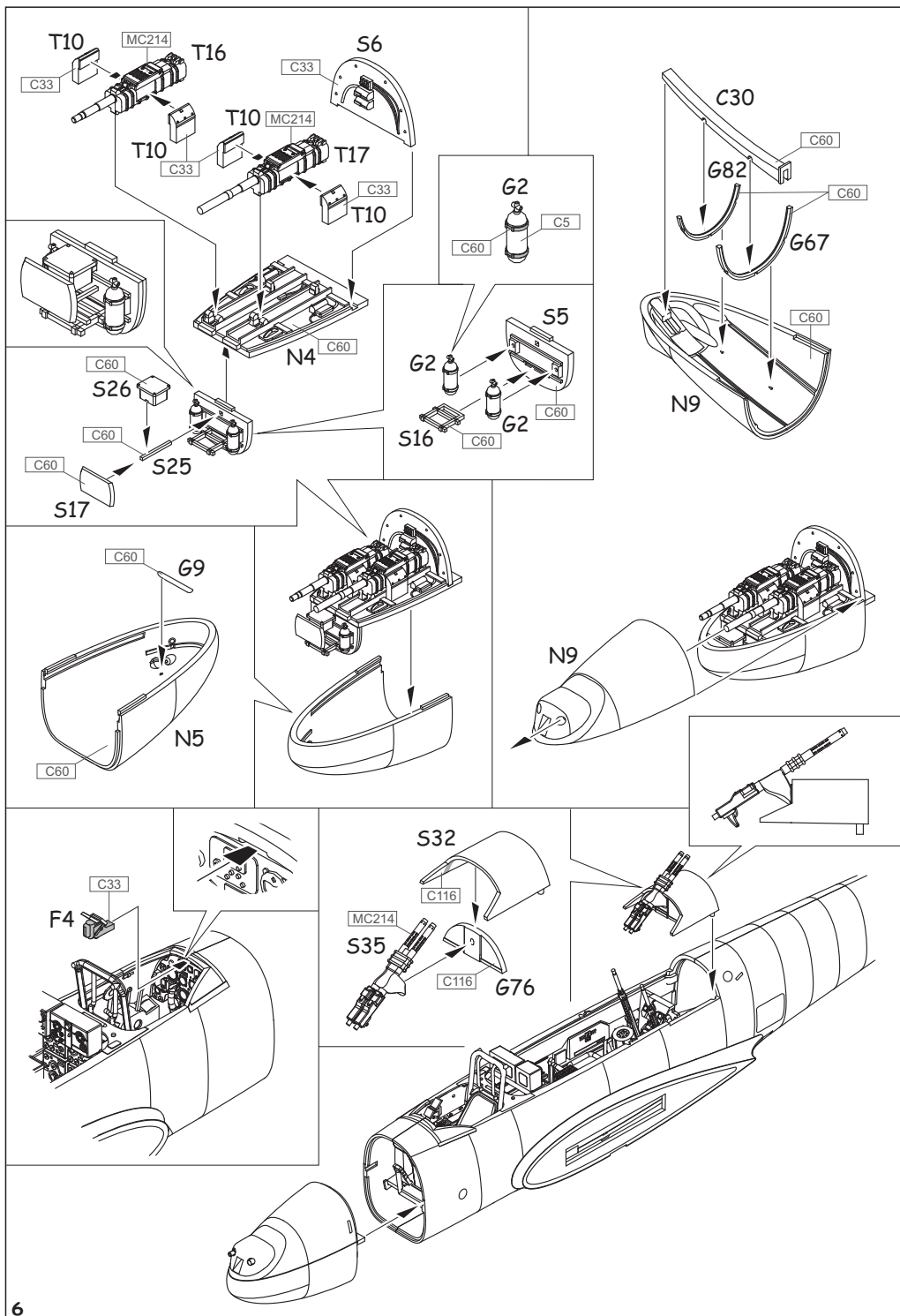

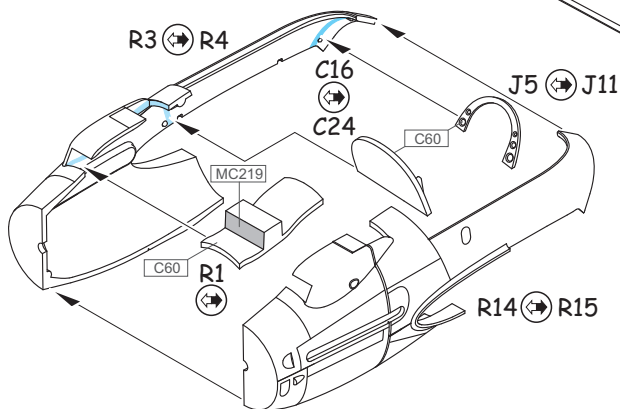
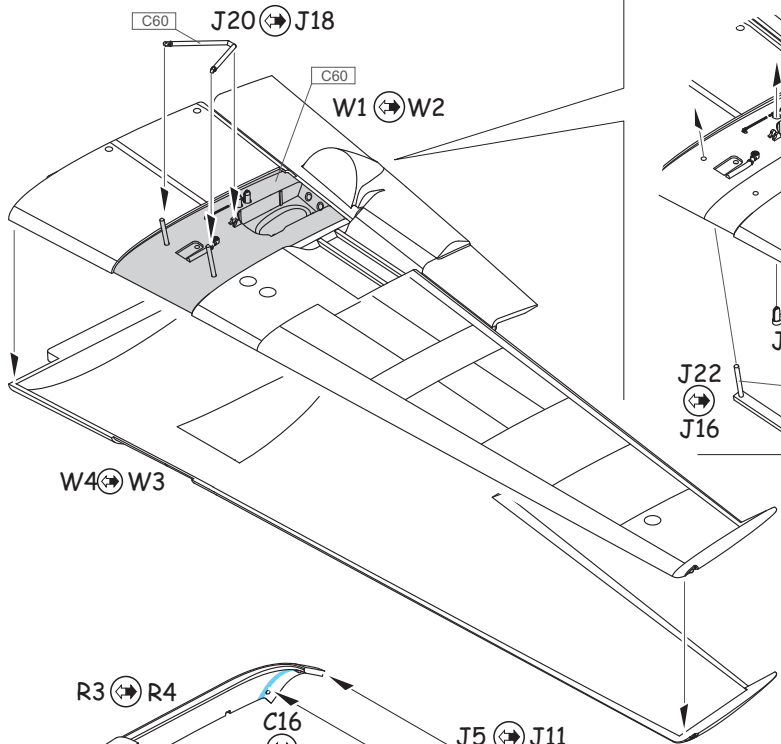
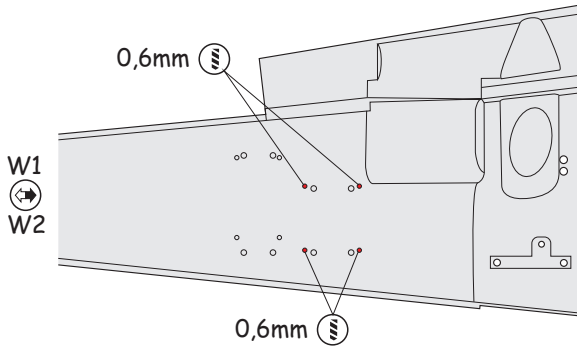

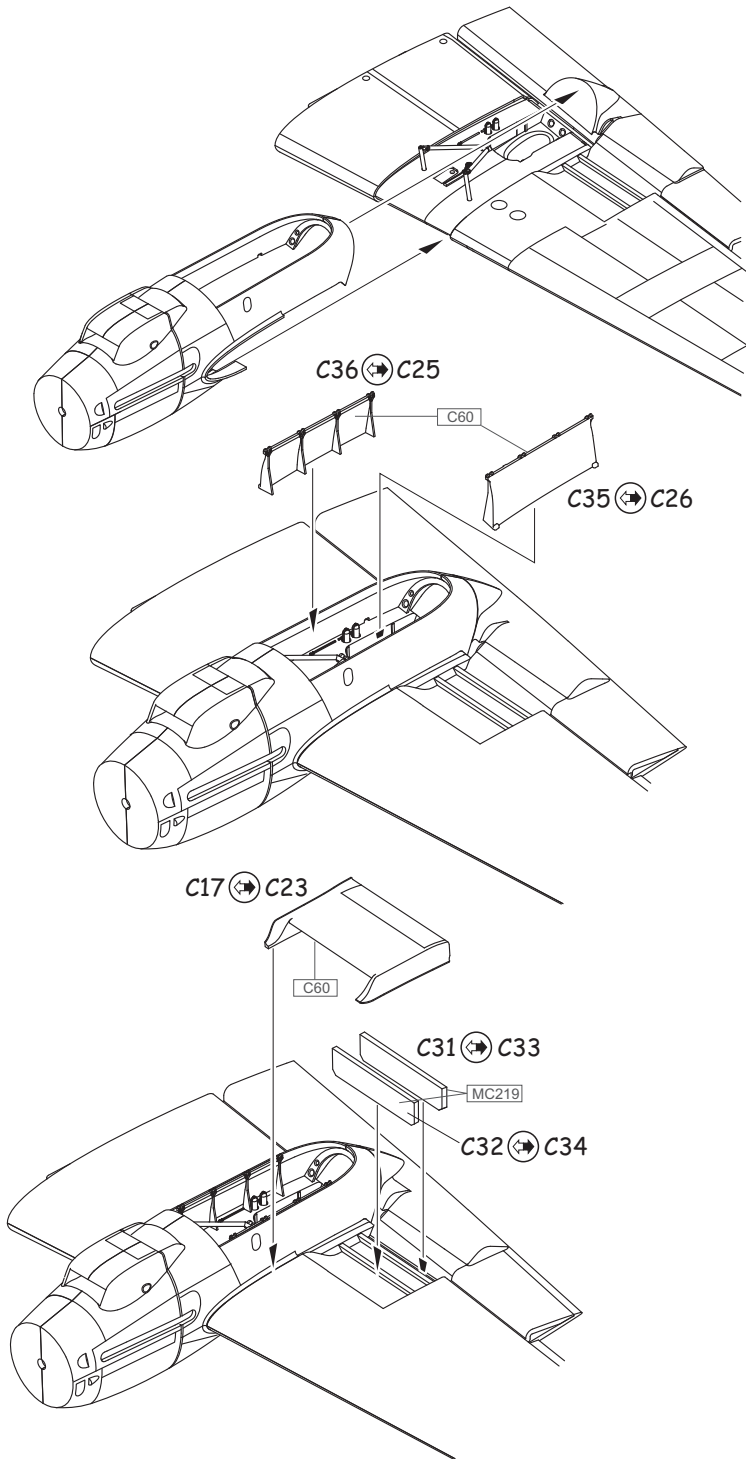



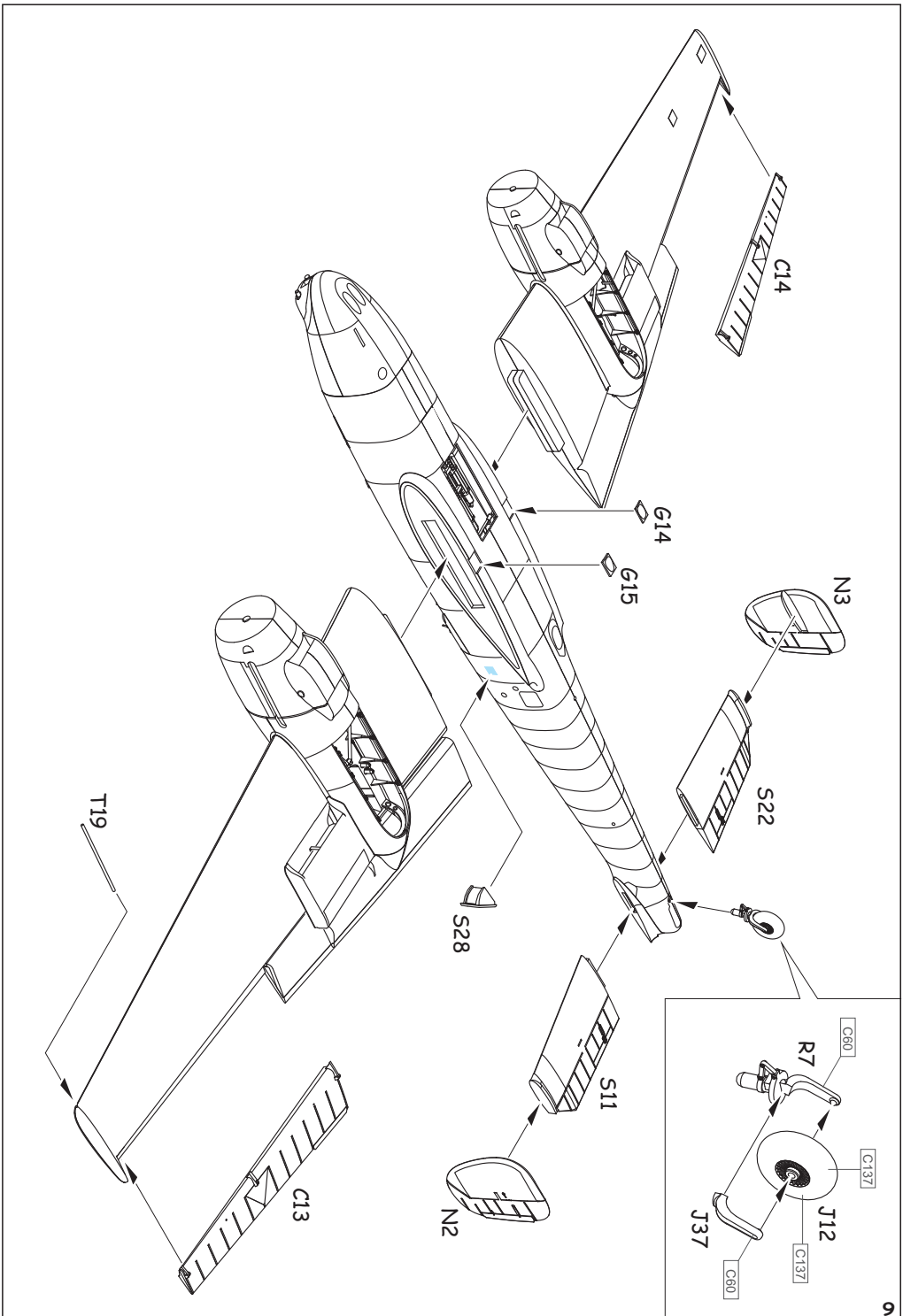

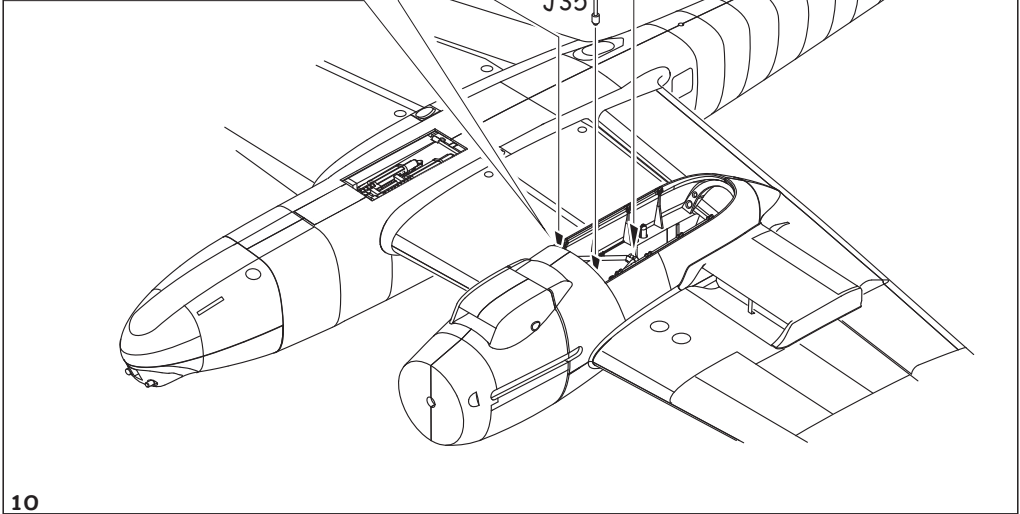
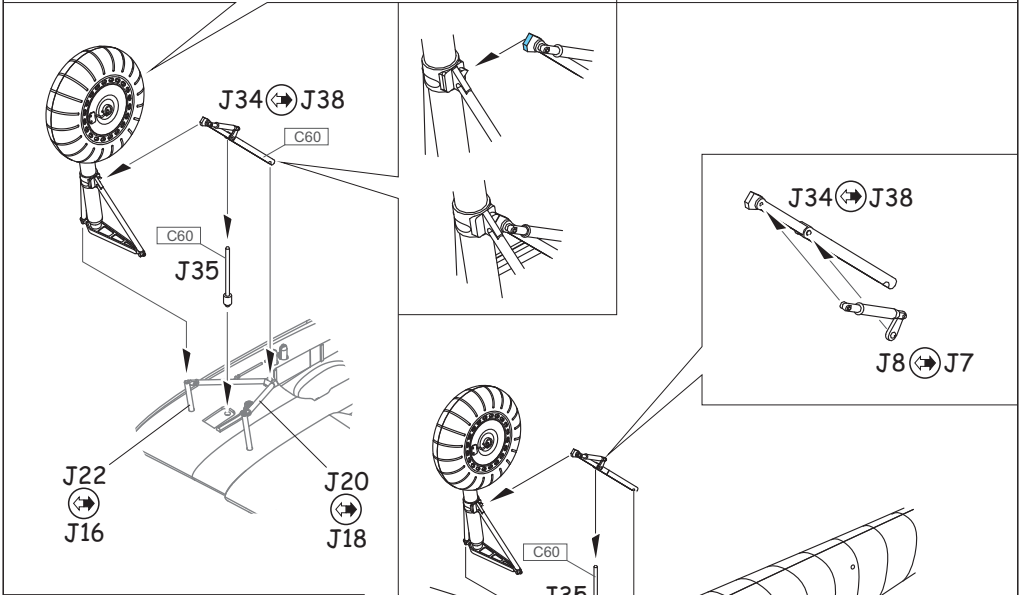
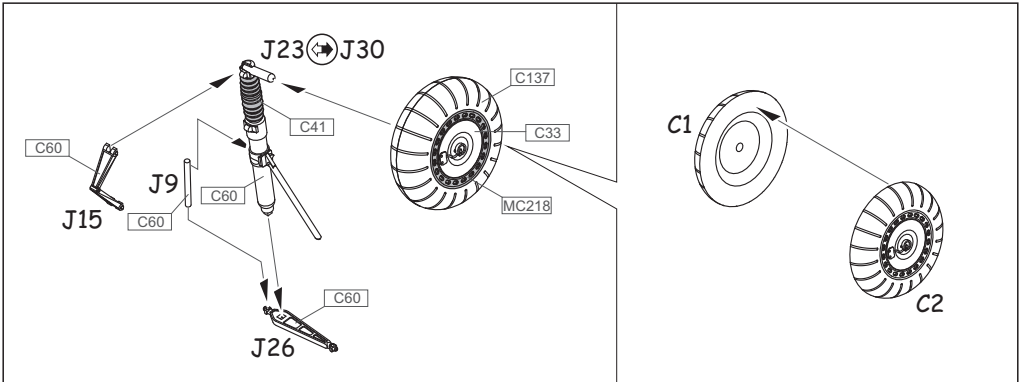

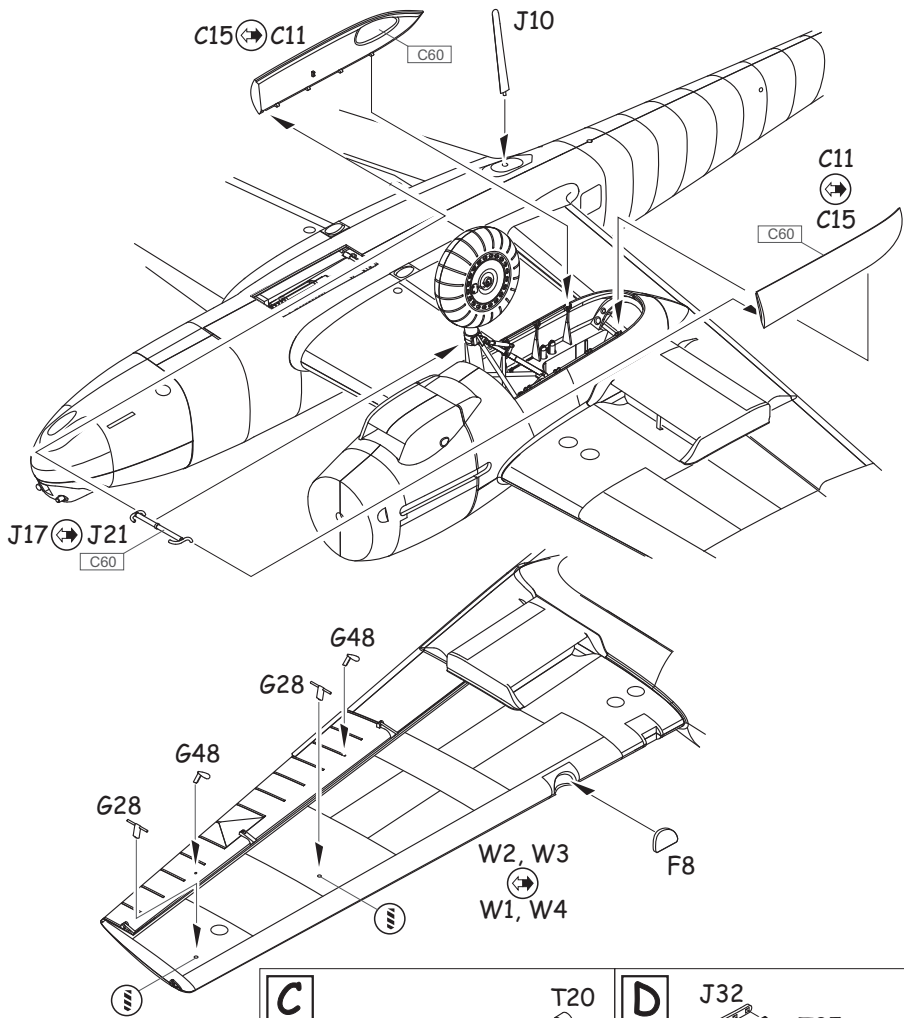

WE RECOMMEND TO GLUE J24/ J32 EXHAUST BASES TO ENGINE NACELLES FIRST, NEXT GLUE THE EXHAUST PIPES TO THE BASES.

DOPORUČUJEME NEJPRVE NALEPIT ZÁKLADNY VÝFUKŮ J24/ J32 DO MOTOROVÝCH GONDOL, TEPRVE POTÉ VLEPOVAT JEDNOTLIVÉ VÝFUKY DO SESTAVY.

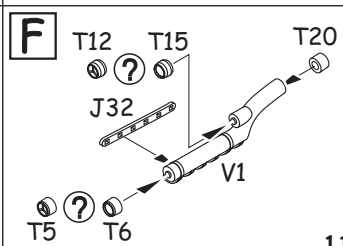
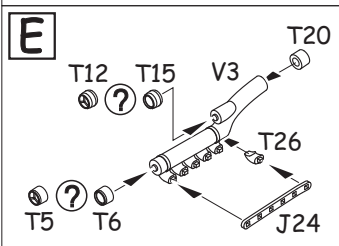
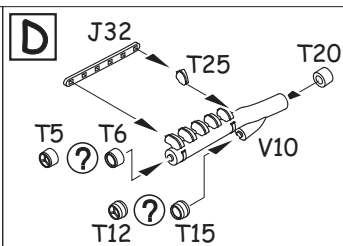
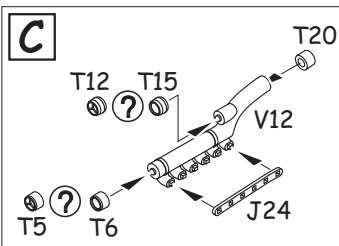

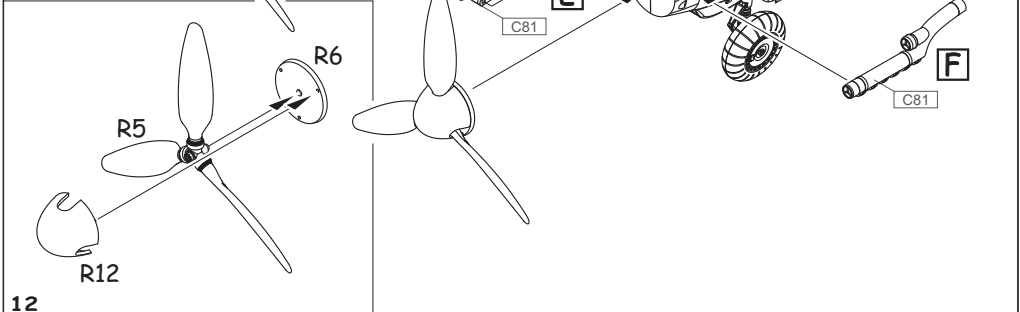
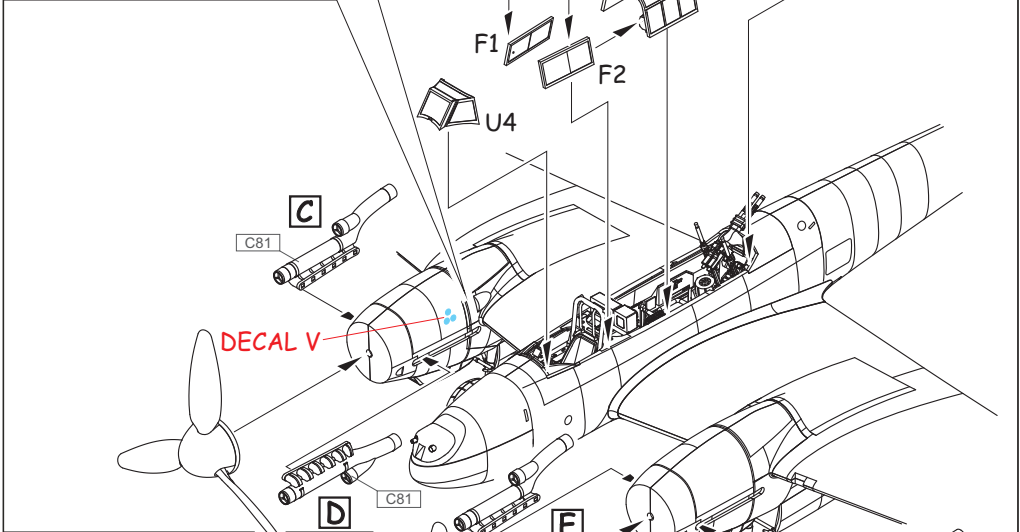
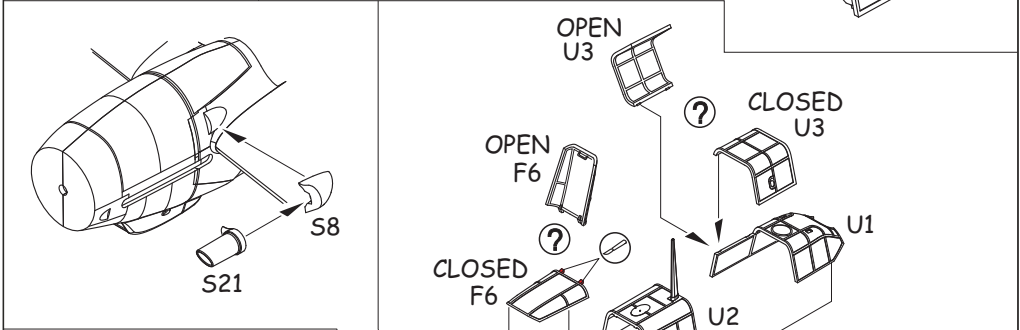
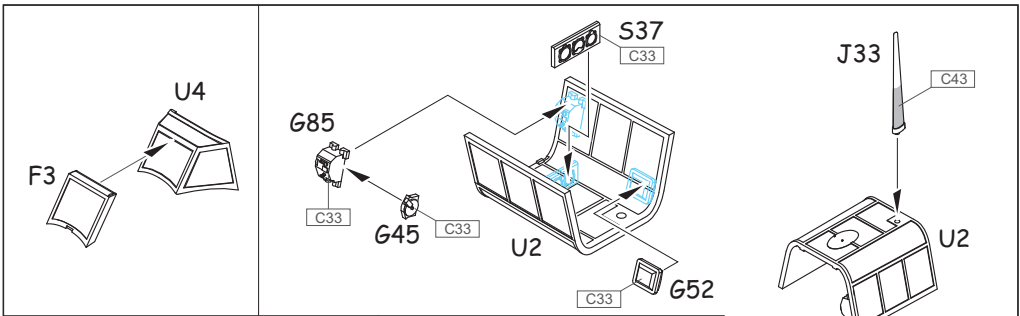

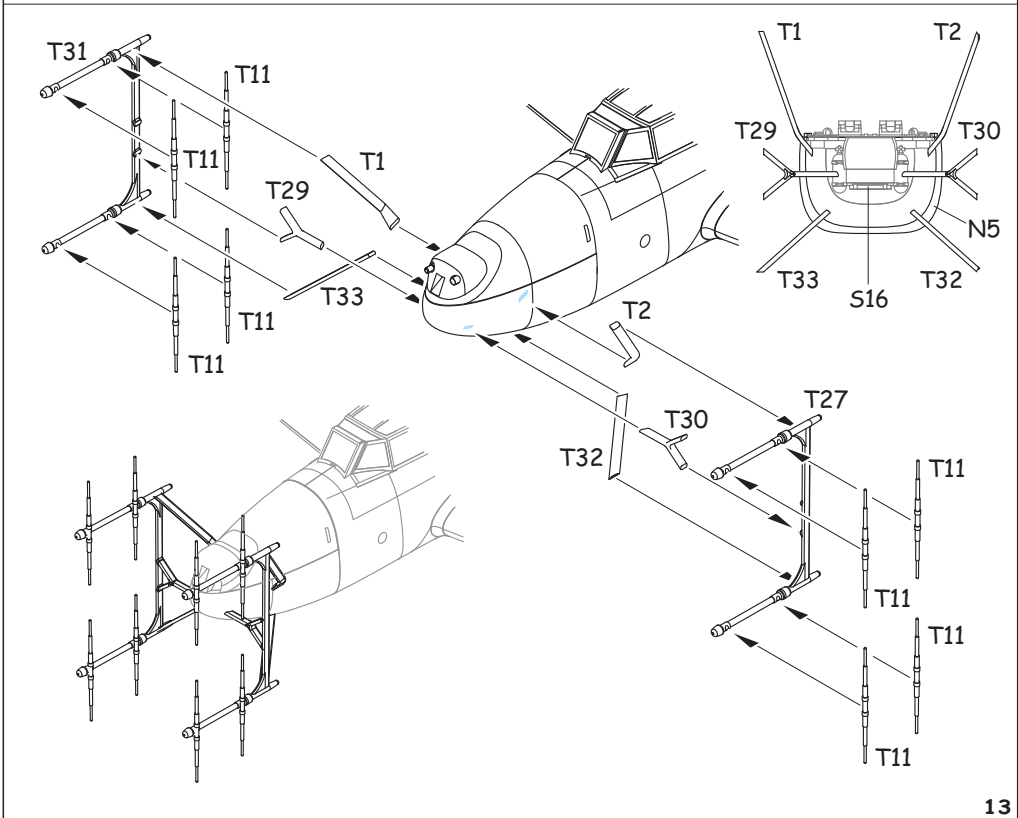
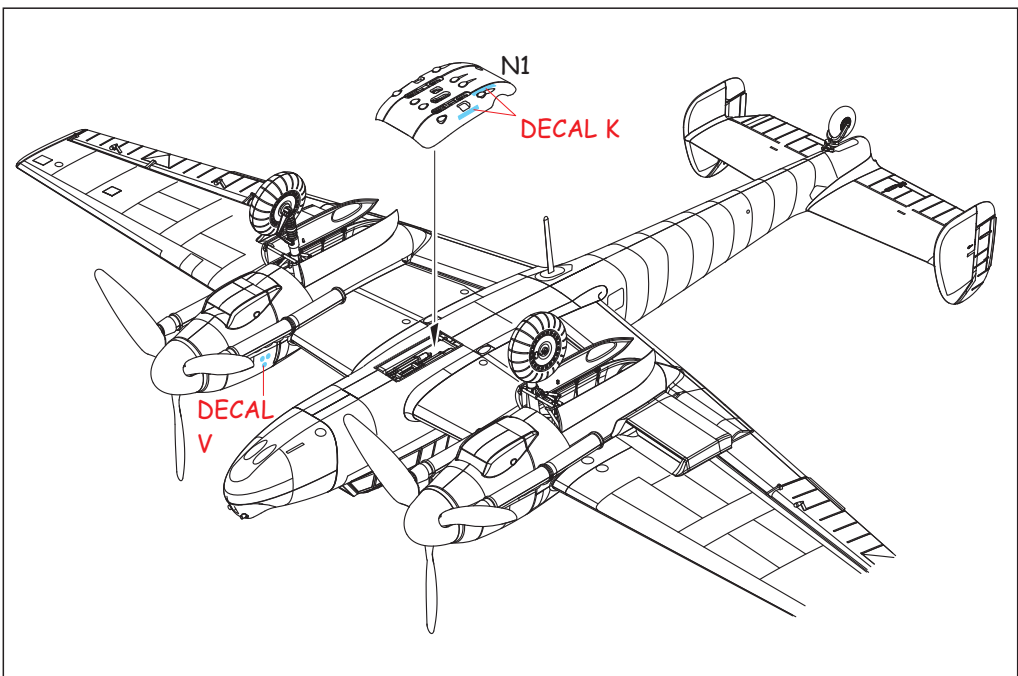



# Wr.Nr. 110087, 4./NJG3, Kjevik, Norway, 1945

4./NJG 3 was formed in March, 1945, out of Nachtjagdstaffel Norwegen, a unit that operated independently from Norway. The purpose of the unit was to intercept allied aircraft over Scandinavia. Besides the Bf110G, the unit also flew the Ju88G and He219. Its last function was on May 8, 1945, evacuating German unit officers from the surrounding areas. Aircraft B4+KA probably did not take part in this final action, because the end of the war found the aircraft still at Kjevik, in Norway. The aircraft carried FuG 220 SN-2b with vertical dipoles, and with an older type of mounting. It carried a camouflage scheme of irregular fields of RLM 76 and RLM 75 on upper surfaces, and RLM 76 on the lower surfaces. The lower surface of the starboard wing and engine cowl were oversprayed in black. This aircraft is recorded as crewed by Fw. Kurt Kellig (pilot), Fw. Kurt Schroter (radio operator) and Uffz. Karl Stamminger (mechanic).

CELOBAREVNÝ NÁVOD NA WWW.EDUARD.COM

FIND FULL COLOR INSTRUCTION ON WWW.EDUARD.COM

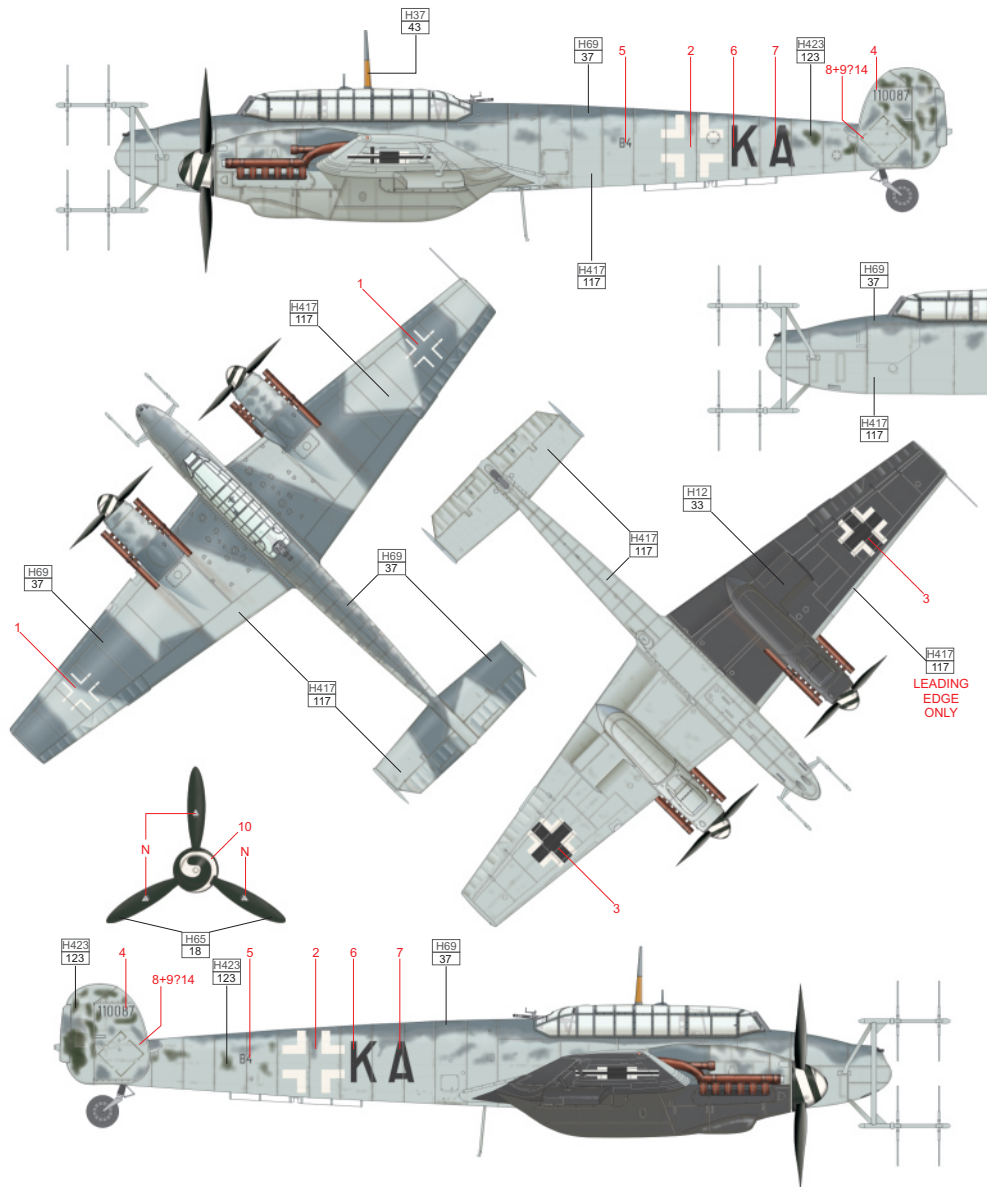

RLM 76	H417 117	RLM 75	H69 37	RLM 83	H423 123	RLM 70	H65 18	WOOD	H37 43	BLACK	H12 33
--------	----------	--------	--------	--------	----------	--------	--------	------	--------	-------	--------





8433  
F6F-3  
Hellcat

8433  
P-39Q  
Airacobra



8433  
Fw 190A-5

8433  
Fw 190A-8



8433  
I-16  
TYPE 24

8433  
La-7

