

GERMAN WWII FIGHTER

1:32 SCALE PLASTIC KIT



eduard

Bf 109 intro

No other aircraft of the German Luftwaffe is so intimately connected with its rise and fall in the course of the Second World War than the Messerschmitt Bf 109. This type, by whose evolution outlived the era in which it was conceptualized, bore the brunt of Luftwaffe duties from the opening battles of Nazi Germany through to her final downfall. The history of the aircraft begins during 1934-35, when the Reich Ministry of Aviation formulated a requirement for the development of a single-engined monoplane fighter. Proposals were submitted by Arado, Heinkel, Focke-Wulf and Bayerische Flugzeugwerke. The last mentioned firm featured a technical director named Professor Willy Messerschmitt, who was riding a wave of popularity based on the success of his recent liaison aircraft, the Bf 108. His goal was to conceive of an aircraft with the best possible performance for the specified weight, size, and aerodynamic qualities. Over the subsequent months, several prototypes were built that served first and foremost in development flights and further modifications. The aircraft was relatively small, and compared to the prevailing trends of the time, docile with revolutionary features such as low wing design, the use of a retractable landing gear, a wing with a very narrow profile, wing slats, landing flaps, weapons firing through the prop arc, and so on. Even the enclosed cockpit and the method of construction were not very common just four years prior to the beginning of the Second World War. At its conception, the Bf 109 was a very promising asset despite some powerplant troubles. These were solved by the introduction of the DB601. This engine, together with its extrapolated development DB605, are umbilically connected to the types success. These two-row, twelve cylinder inverted V engines powered several tens of thousands of '109s in over 25 versions and variants.

The first combat use was by three developmental Bf 109s in the Spanish Civil War, where they were delivered in December, 1936. The pre-series airframes were to, first of all, validate the aircraft's abilities in modern aerial combat. Shortly thereafter, production machines in the form of the Bf 109B-1 began to reach 2./J.88, the Legion Condor. The desire of Germany to demonstrate her aerial prowess to potential foes was advanced further in international sport meets. The triumphs attained in Zurich in the summer of 1937 were complemented several months later by grabbing the speed record of 610.95 kph. In very short order, the progressive developments represented by the C, D and E versions appeared. Despite this, the delivery of the types to combat units did not sustain a rate that was desired by military brass. Even by August, 1938, the Bf 109 accounted for less than half of the 643 front line fighters in service. The later months saw an increase in these rates. By the time of the invasion of Poland (which saw the participation of only a little more than 200 aircraft) the Luftwaffe possessed the best fighter produced in continental Europe. With both a qualitative and quantitative advantage, the fighter wing of the Luftwaffe entered the Polish campaign, the first defenses of the Fatherland, Blitzkrieg against the West, and the Battle for France. With one foot in the door that was the English Channel, the Luftwaffe embarked on the attacks on Britain in the summer months of 1940. Here, the first weakness of the Bf 109 was revealed: the inability to carry drop tanks that would have enabled the type to effectively escort bombers to England. This was one of the factors that made the defeat of the Luftwaffe in the Battle of Britain possible. Experiences gained in 1940 led to the development of the 'F' version prior to the spring of 1941. The elegance of the Bf 109 crested with the 'Friedrich'. Following a largely defensive stance over the Channel and northern France, the Bf 109F took on a more offensive role in Operation Barbarossa in the east, and in northern Africa. In later duties with the 'Jagdwaaffe' during the second phase of the war in the east, and in the 'Defense of the Reich' from 1943 to 1945, the Bf 109 served in the form of the 'G' version, followed by the 'K'. Even if by the end of the war it was clear that the development of the Bf 109 was exhausted, during its combat career, the type was able to keep pace with the foes that it encountered. Besides its primary function as fighter, the Bf 109 also appeared as a fighter-bomber, reconnaissance platform, night fighter, trainer and rammjager.

The disappearance of the Bf 109 from the skies over Europe was not spelled out by the end of the war. Bf 109s served in Balkan countries (Yugoslavia and Bulgaria), several examples were in Swiss service up to 1949, and many flew in the air force of Czechoslovakia in both original form with a DB605 powerplant and as aircraft built out of necessity with surplus Jumo 211s. The latter type also served as the first fighter to fight for the independence of the newly formed state of Israel. Finland retired the type as recently as 1954, and Spain didn't retire its HA-1109-1112, rebuilt Bf 109s, until 1967. The legendary low-wing fighter of Professor Willy Messerschmitt survived the state that developed it.

The Bf 109E-3 version

The E-3 was the sister version to the E-1 developed from the prototype Bf 109V15. The 'Emil' was the first version where the DB 601 replaced the Jumo 210. Not only did the front of the aircraft change significantly with this modification, but the engine drove a three blade, variable pitch propeller, and gave a 50% better performance. Standard armament of the E-3 comprised twin MG17 machine guns above the engine, and 20mm MG/FF cannon in the wings (both the E-1 and the E-3 were produced simultaneously, differing only in wing armament). There was a total of approximately 6000 Emilis built. Compared to its adversaries, comprising chiefly of the D-520, Spitfire and Hurricane, the E-3 enjoyed an advantage in climb rate, armament, stability as a gun platform, and having fuel injection. Its main drawback ended up being short range, allowing only a few minutes' combat before the pilot needed to break off and head back to his home field. Shortly after the Battle of Britain, the Bf 109E-3 and E-1 were replaced by later 'E' and the 'F' versions.

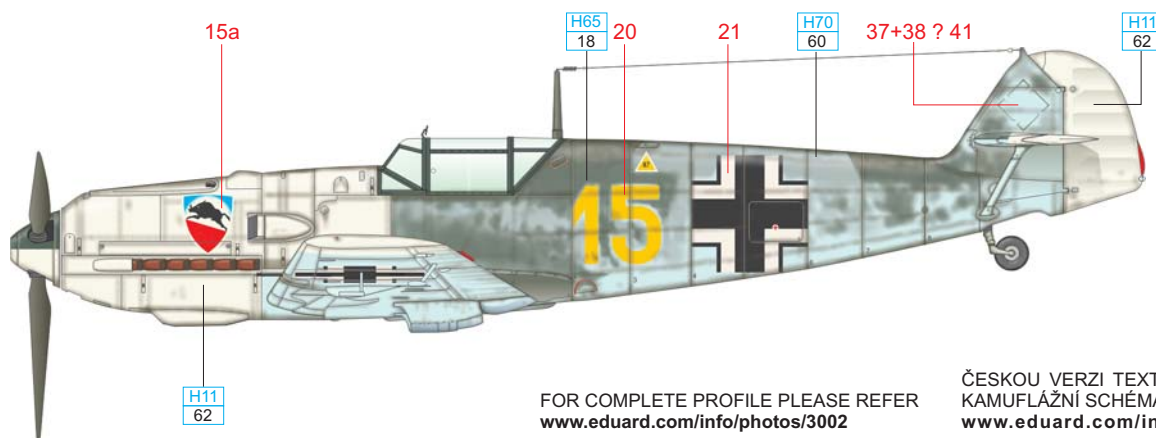

FOR COMPLETE PROFILE PLEASE REFER
www.eduard.com/info/photos/3002

ČESKOU VERZI TEXTU A KOMPLETNÍ
 KAMUFLÁŽNÍ SCHÉMA NALEZNETE NA
www.eduard.com/info/photos/3002

E Uffz. Karl Wolff, 3./JG 52, Pihen/Calais, France, August 1940

A very attractive scheme was carried by Bf 109E-3 White '15', with which Uffz. Karl Wolff crashed on landing on August 30, 1940. It carried the standard scheme of RLM 02/7 1/65, and the light blue 65 extended up the fuselage sides. The light blue, which also wrapped around the leading edges of the wings, was subdued with overspray of colors used on the upper surfaces. Furthermore, the aircraft received white paint on surfaces such as the nose, rudder and wingtips, used first and foremost as quick identification features. The I. Gruppe JG 52 unit emblem appeared on the nose of the plane. A month after his hard landing in White '15', Uffz. Wolff was shot down and taken prisoner.

Jagdgeschwader 52 became the Luftwaffe's most successful fighter unit mainly due to its operations over the Eastern Front. However, its successes began during the Battle of France, and later, the Battle of Britain. By the end of 1940, the unit's pilots had already racked up 177 kills. On the other hand, losses were quite high as well. Just during the Battle of Britain, the unit lost 53 pilots. The unit was also odd in that its equipment over the course of the war was composed exclusively of Bf 109s.

Additional sources: *Classic Colours: Jagdwaaffe / Attack in the West and Battle of Britain series by Eric Mombeek*

ATTENTION



UPOZORNĚNÍ



ACHTUNG



ATTENTION



注意



Carefully read instruction sheet before assembling. When you use glue or paint, do not use near open flame and use in well ventilated room. Keep out of reach of small children. Children must not be allowed to suck any part, or pull vinyl bag over the head.



Před započetím stavby si pečlivě prostudujte stavební návod. Při používání barev a lepidel pracujte v dobře větrané místnosti. Lepidla ani barvy nepoužívejte v blízkosti otevřeného ohně. Model není určen malým dětem, mohlo by dojít k požití drobných dílů.



lire soigneusement la fiche d'instructions avant d'assembler. Ne pas utiliser de colle ou de peinture à proximité d'une flamme nue, et aérer la pièce de temps en temps. Garder hors de portée des enfants en bas âge. Ne pas laisser les enfants mettre en bouche ou sucer les pièces, ou passer un sachet vinyl sur la tête.



Von dem Zusammensetzen die Bauanleitung gut durchlesen. Kleber und Farbe nicht nahe von offenem Feuer verwenden und das Fenster von Zeit zu Zeit Belüftung öffnen. Bausatz von kleinen Kindern fernhalten. Verhüten Sie, daß Kinder irgendwelche Bauteile in den Mund nehmen oder Plastiktüten über den Kopf ziehen.



組み立てる前に必ず説明書をお読み下さい。接着剤や塗料をご使用の際は、窓を開けて十分な換気をおこない、火のそばでは使用しないで下さい。小さな子供の手の届かない所に必ず保管してください。部品や破片を噛んだり、なめたり、飲んだりすると大変危険です。又、部品を取り出した後のビニール袋は、小さな子供が頭から被ったりすると窒息する恐れがありますので、破り捨てして下さい。

INSTRUCTION SIGNS

* INSTR. SYMBOLY

* INSTRUKTION SINNBILDEN

* SYMBOLES

* 記号の説明



OPTIONAL
VOLBA
FACULTATIF
NACH BELIEBEN
選択する



BEND
OHNOUOT
PLIER SIL VOUS PLAIT
BITTE BIEGEN
折る



OPEN HOLE
VYVRTAT OTVOR
FAIRE UN TROU
OFFNEN
穴を開ける



SYMETRICAL ASSEMBLY
SYMETRICKÁ MONTÁŽ
MONTAGE SYMÉTRIQUE
SYMMETRISCHE AUFBAU
左右均等に組み立てる



NOTCH
ZÁŘEZ
L'INCISION
DER EINSCHNITT
切る



REMOVE
ODŘÍZNOUT
RETIRER
ENTFERNEN
移す



APPLY EXPRESS MASK
AND PAINT
POUŽIT EXPRESS MASK
NABARVIT

PARTS



DÍLY



TEILE



PIÈCES



部品

PLASTIC PARTS

A>

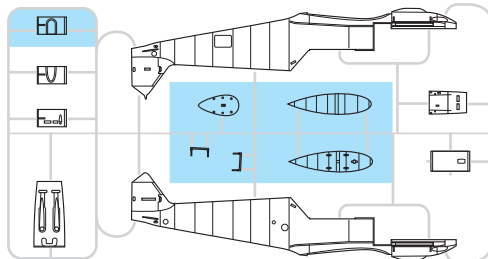

B>

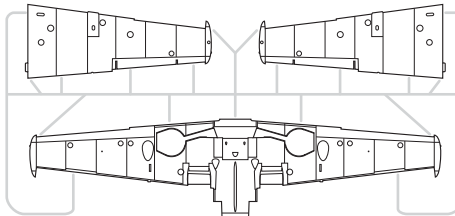

D>

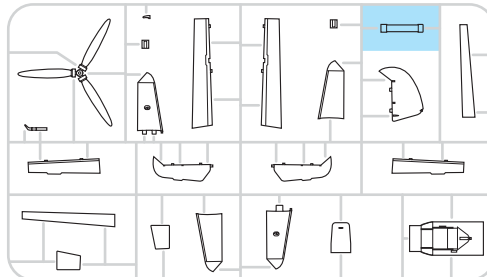

E>

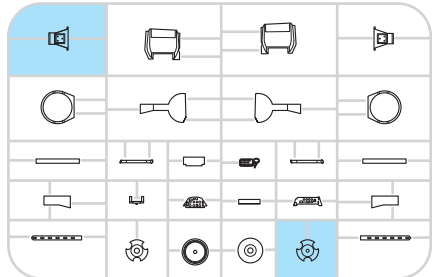

F>

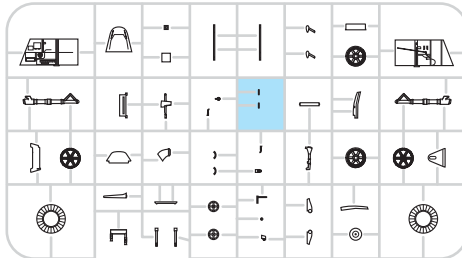

G>

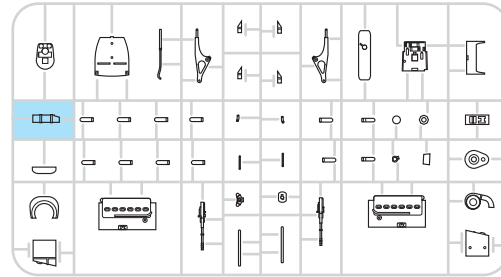

J>

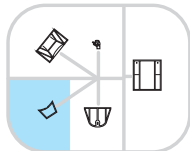

PE - PHOTO ETCHED DETAIL PARTS

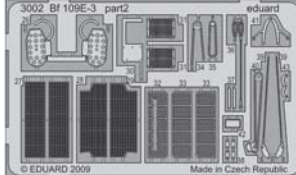
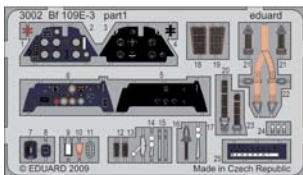
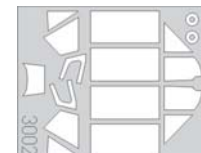
eduard
MASK

-Parts not for use. -Teile werden nicht verwendet. -Pièces à ne pas utiliser. -Tyto díly nepoužívejte při stavbě. - 使用しない部品

COLOURS



BARVY



FARBEN



PEINTURE



色

GSi Creos (GUNZE)			
AQUEOUS	Mr.COLOR		
H4	C4	YELLOW	
H11	C62	FLAT WHITE	
H12	C33	FLAT BLACK	
H47	C41	RED BROWN	
H64	C17	DARK GREEN	RLM 71
H65	C18	BLACK GREEN	RLM 70
H70	C60	GRAY	RLM 02
H77	C137	TIRE BLACK	

AQUEOUS	Mr.COLOR		
H344		RUST	
	C113	YELLOW	RLM 04
	C116	BLACK GRAY	RLM 66
	C117	LIGHT BLUE	RLM 76
Mr.METAL COLOR			
	MC213	STEEL	
	MC214	DARK IRON	
	MC218	ALUMINIUM	

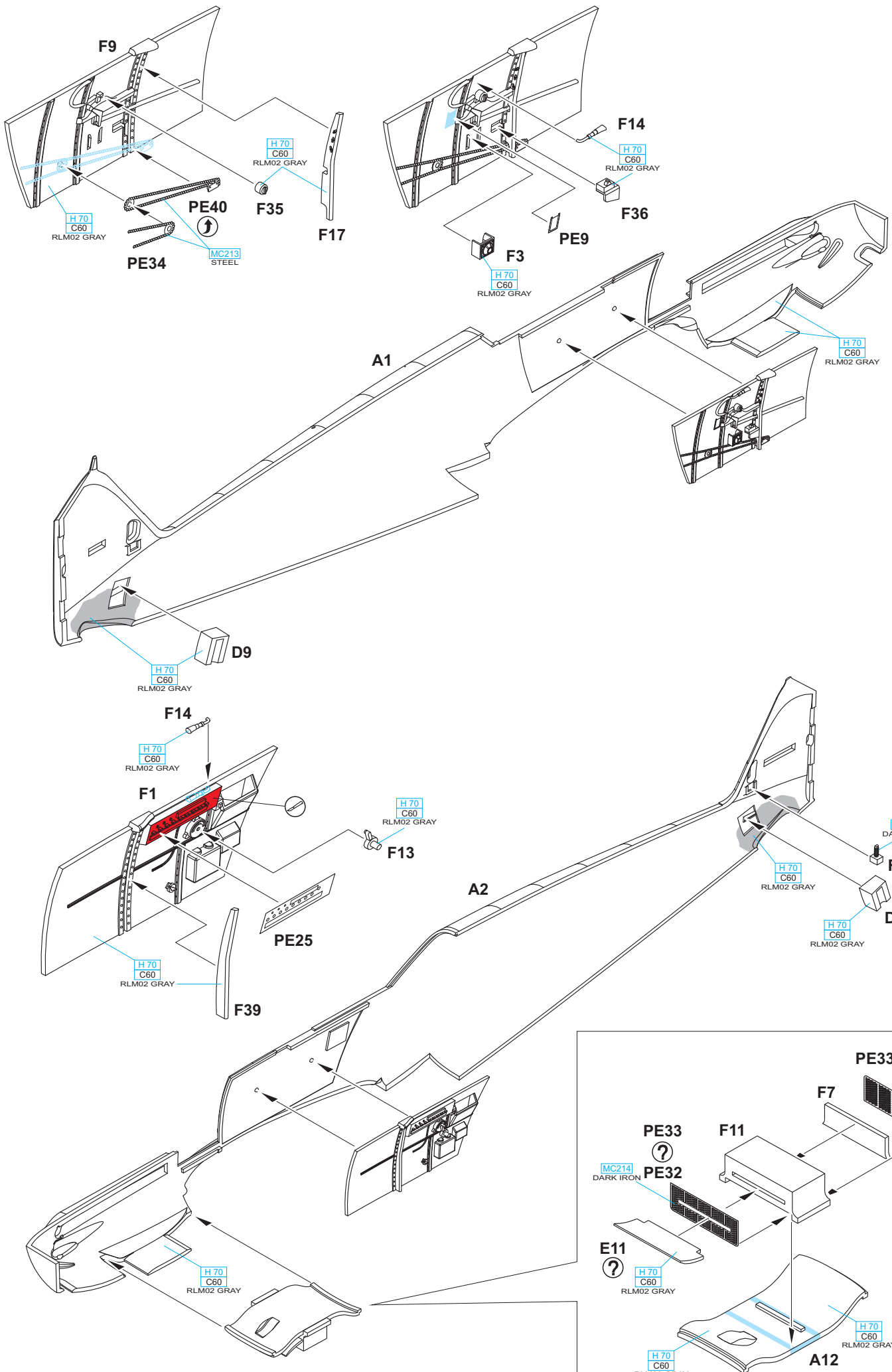

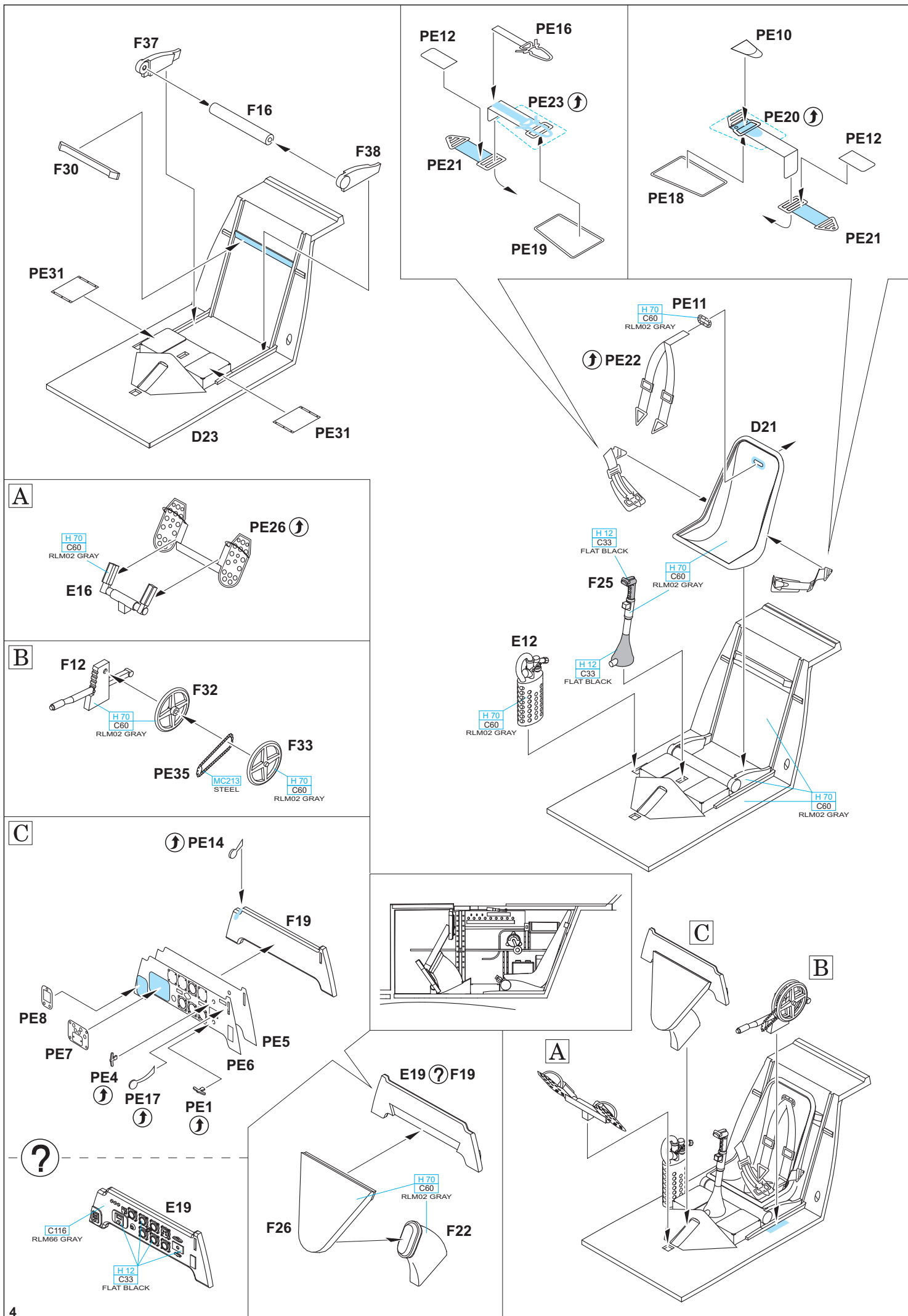

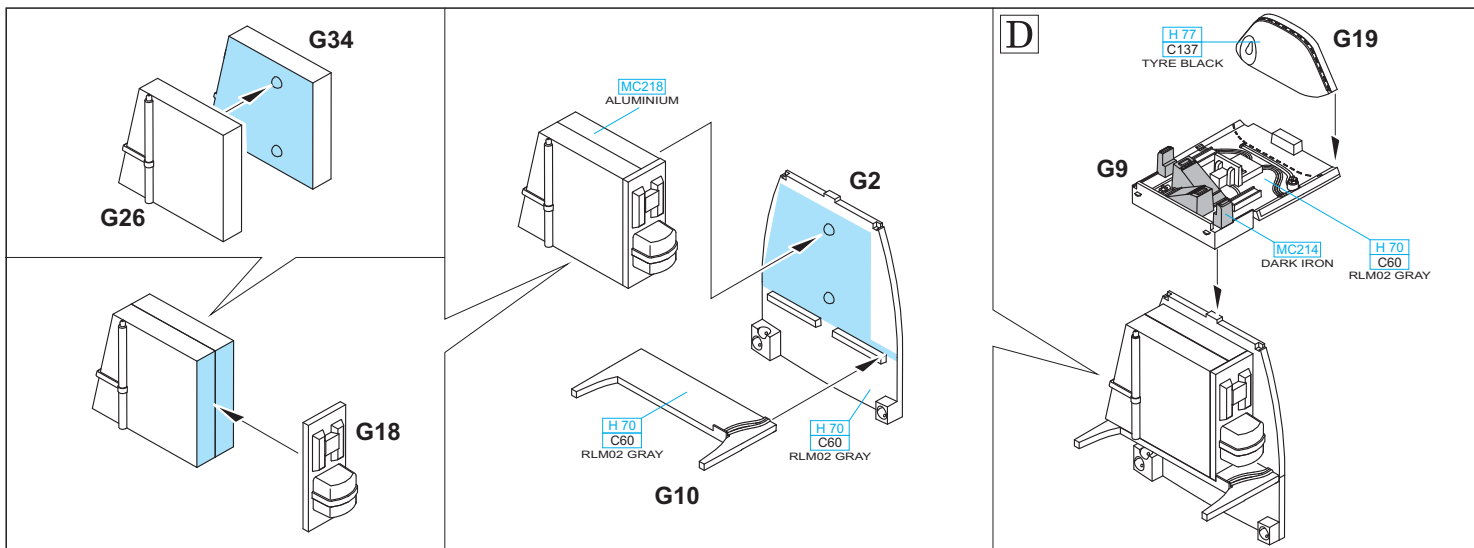

TO BUILD THE MODEL WITH THE CLOSED ENGINE COWLING AND THE WEAPON COVER, YOU CAN'T INSTALL THE COMPLETE ENGINE AND WEAPON ASSEMBLY. FOR MORE INFO PLEASE REFER

www.eduard.com/info/photos/3002

POKUD CHCETE POSTAVIT MODEL SE ZAVŘENÝMI KRYTY MOTORU A TRUPOVÝCH ZBRANÍ, NELZE INSTALOVAT VŠECHNY DETAILY MOTORU A KULOMETŮ. PRO VÍCE INFORMACÍ SE PODÍVEJTE NA

www.eduard.com/info/photos/3002

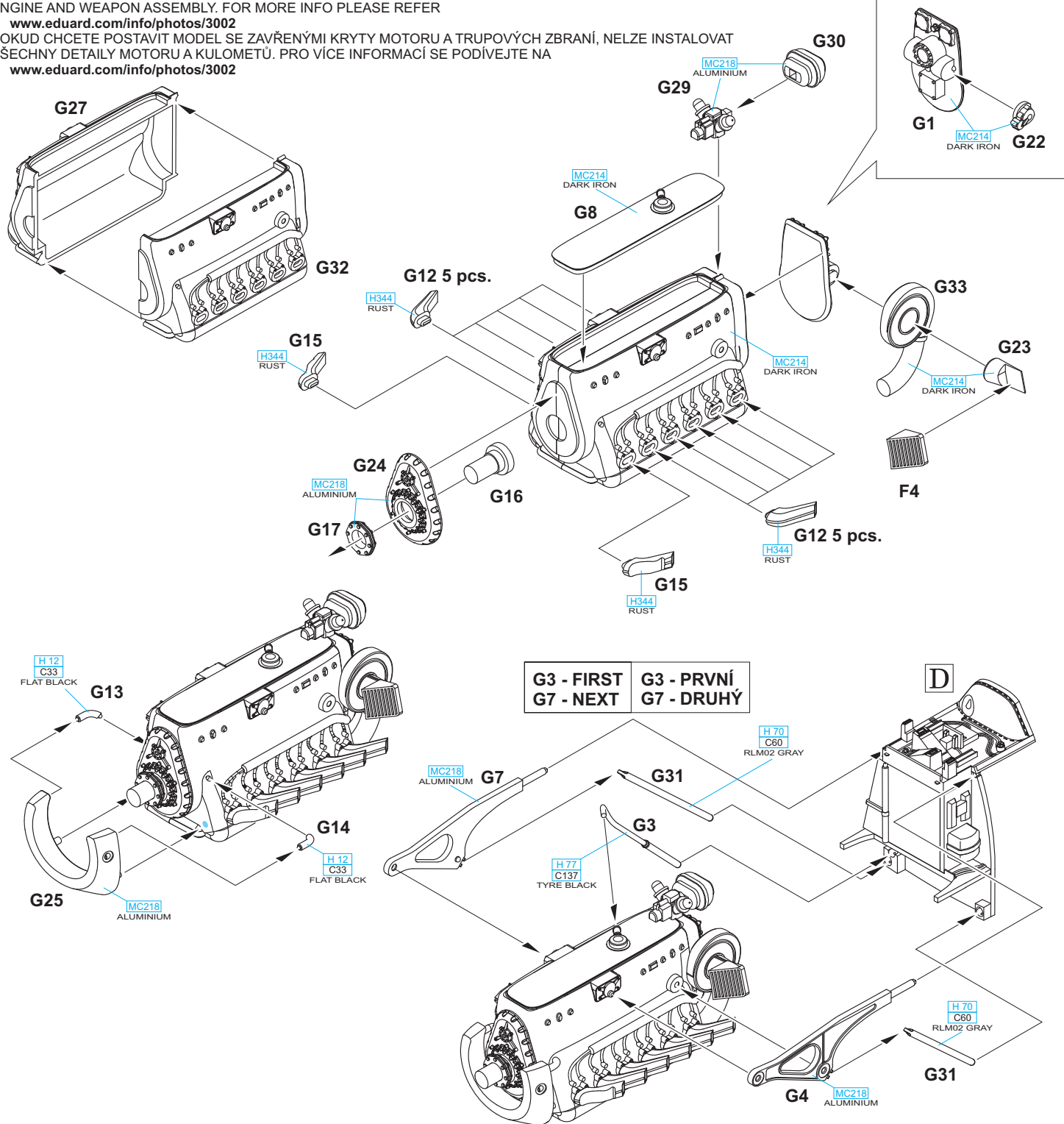

?

E24

G16

D

ALTERNATIVE ASSEMBLY FOR
CLOSED ENGINE COWLING.
ALTERNATIVNÍ SESTAVA PRO
ZAVŘENÝ KRYT MOTORU.

A2

F2

H 70
C60
RLM02 GRAY

A1

F2

D23

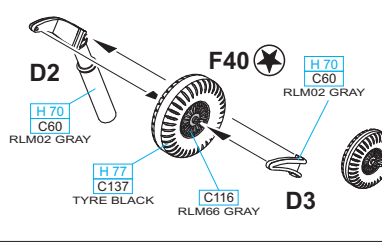
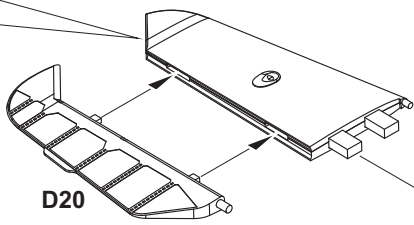
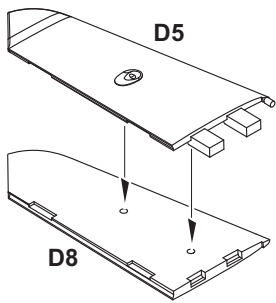

D11

D17

E13

PE39

E10

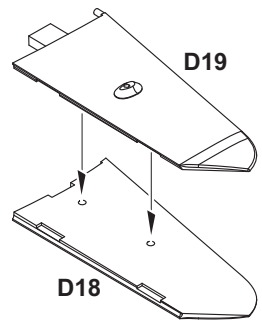

D18

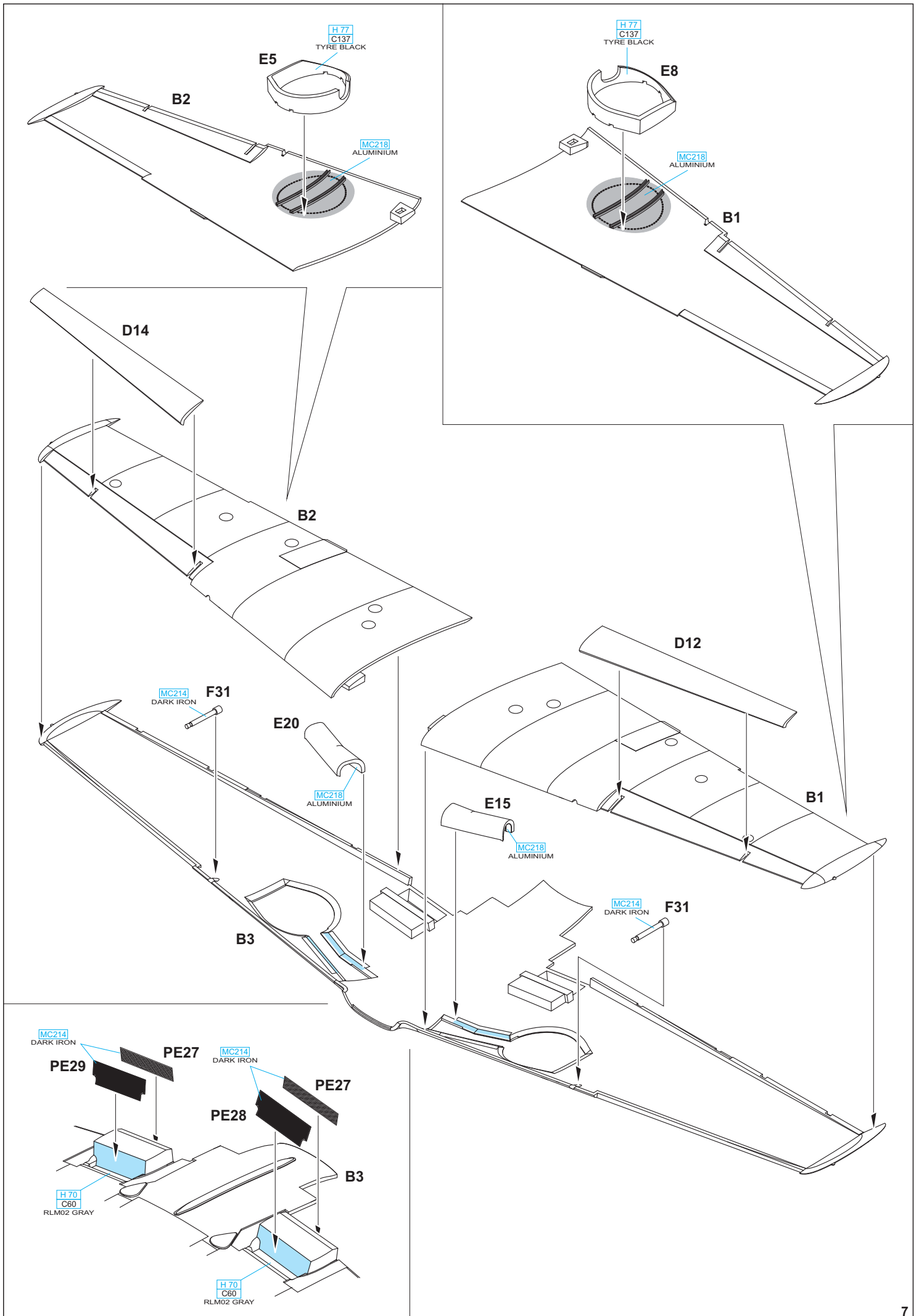

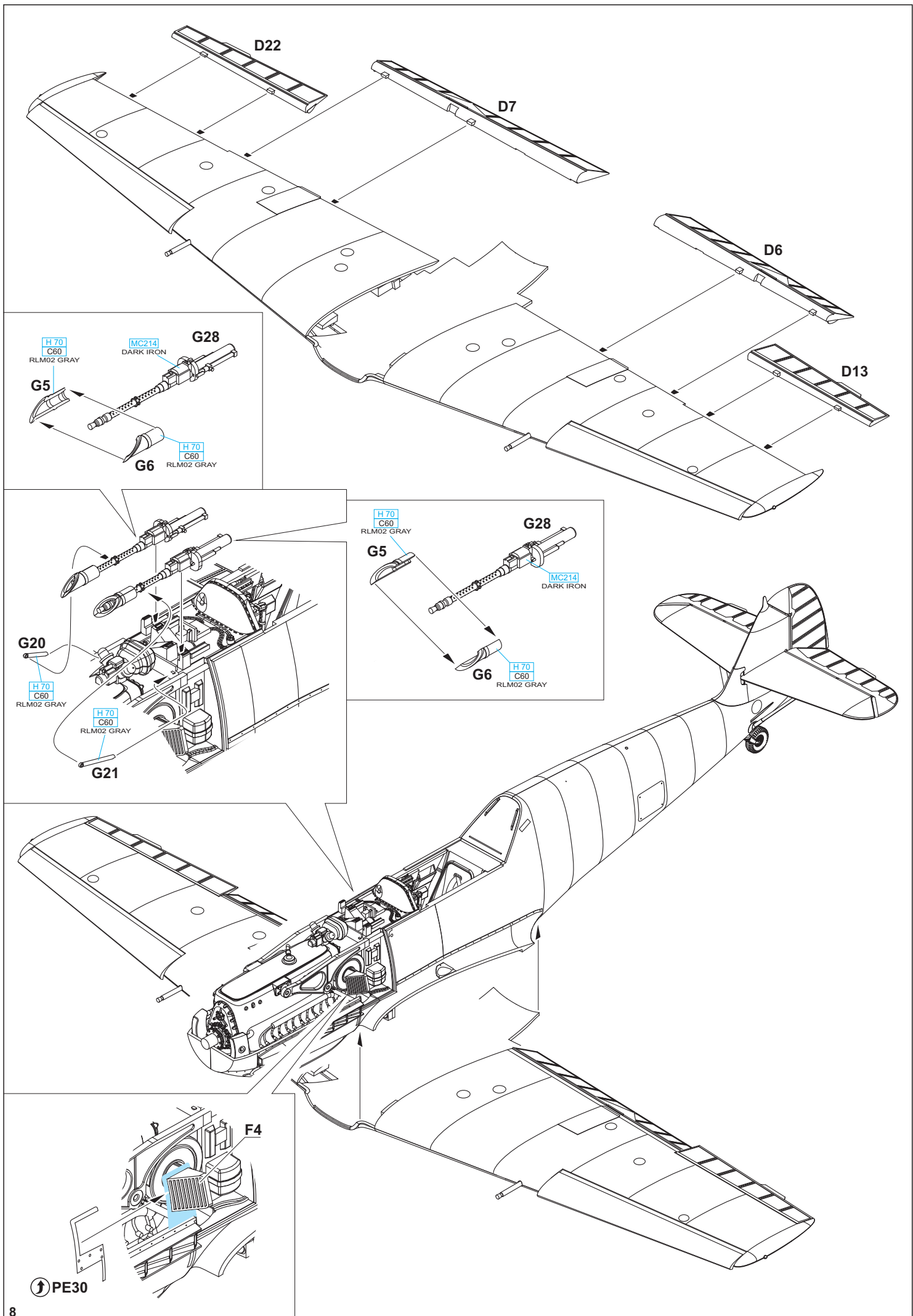

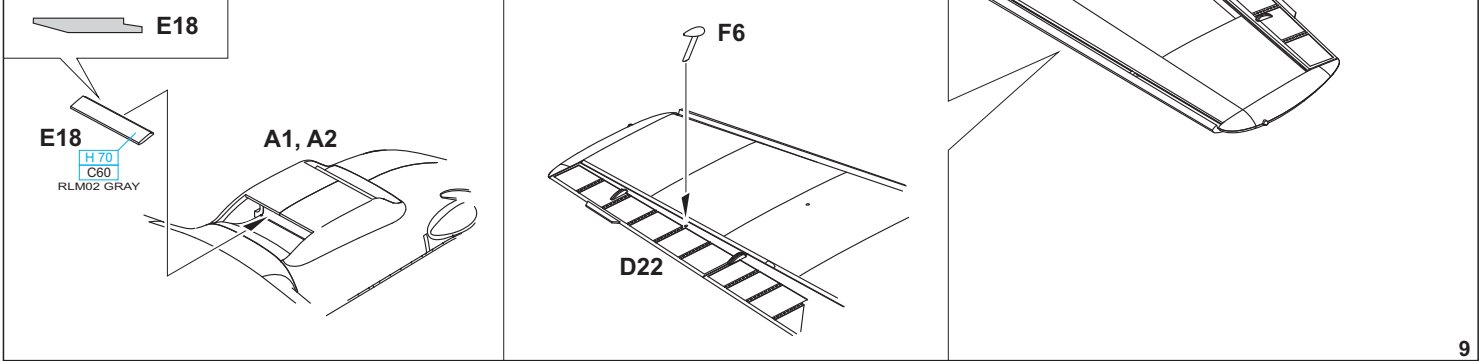
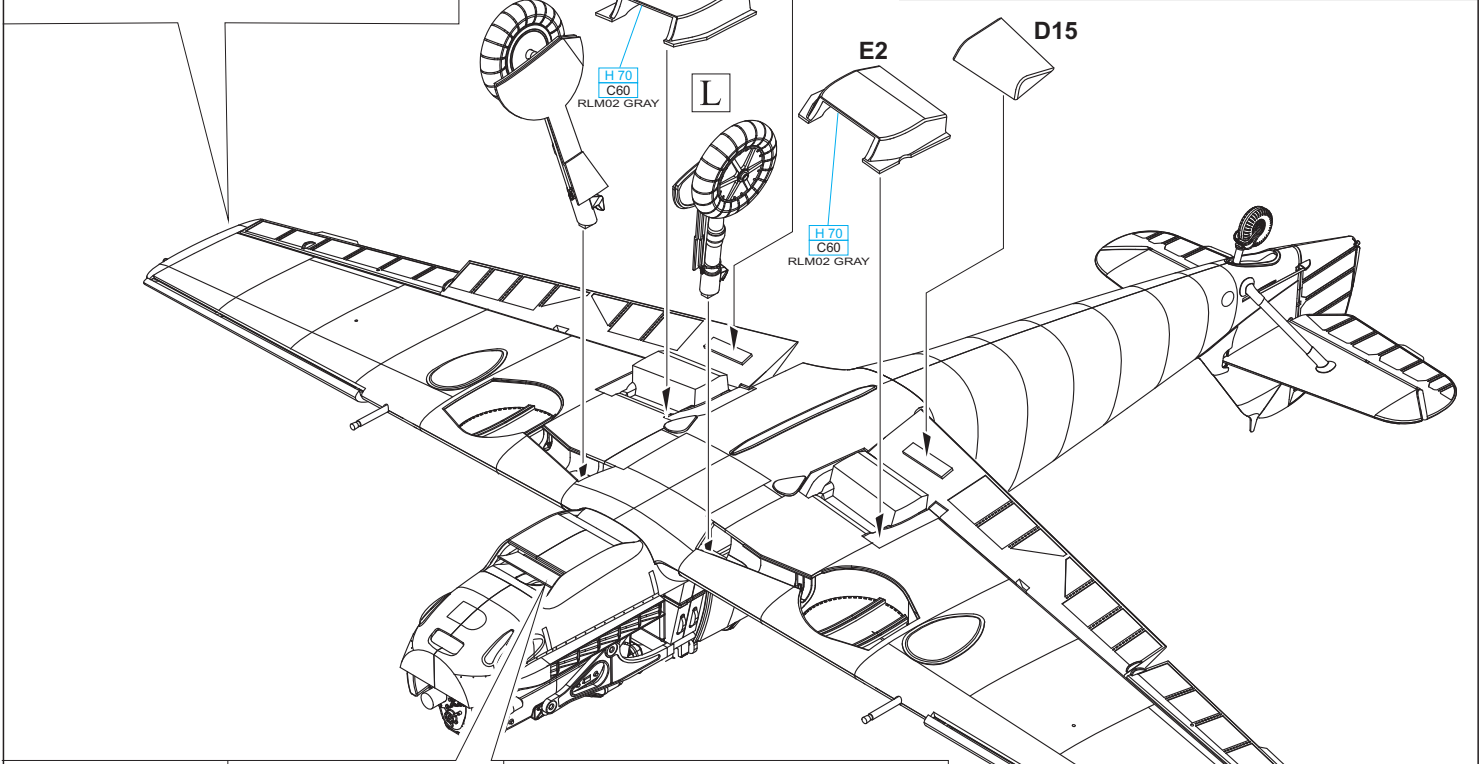
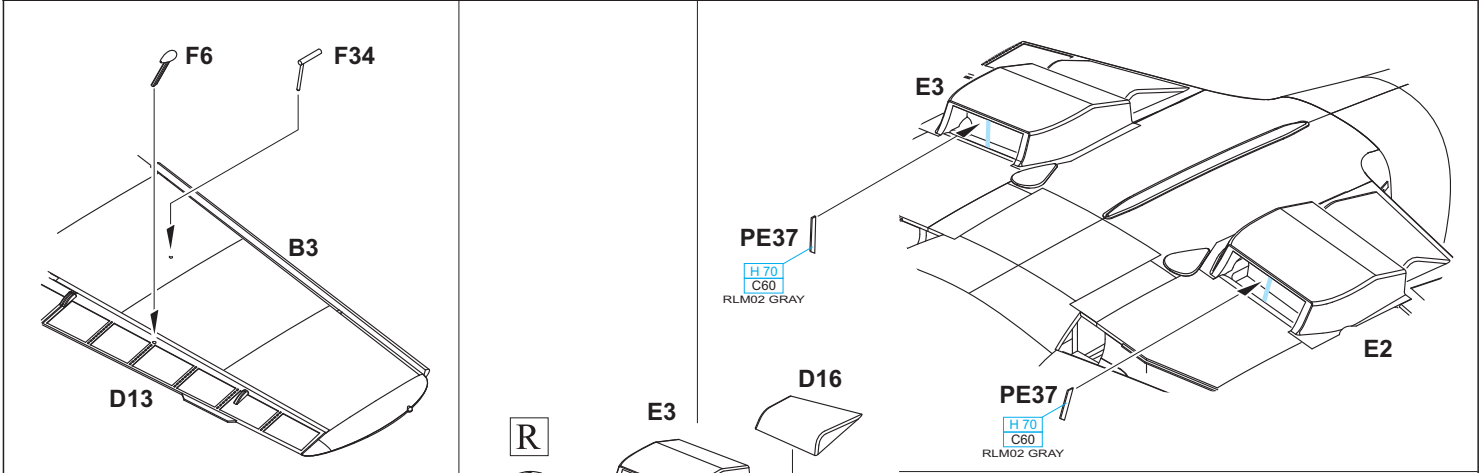
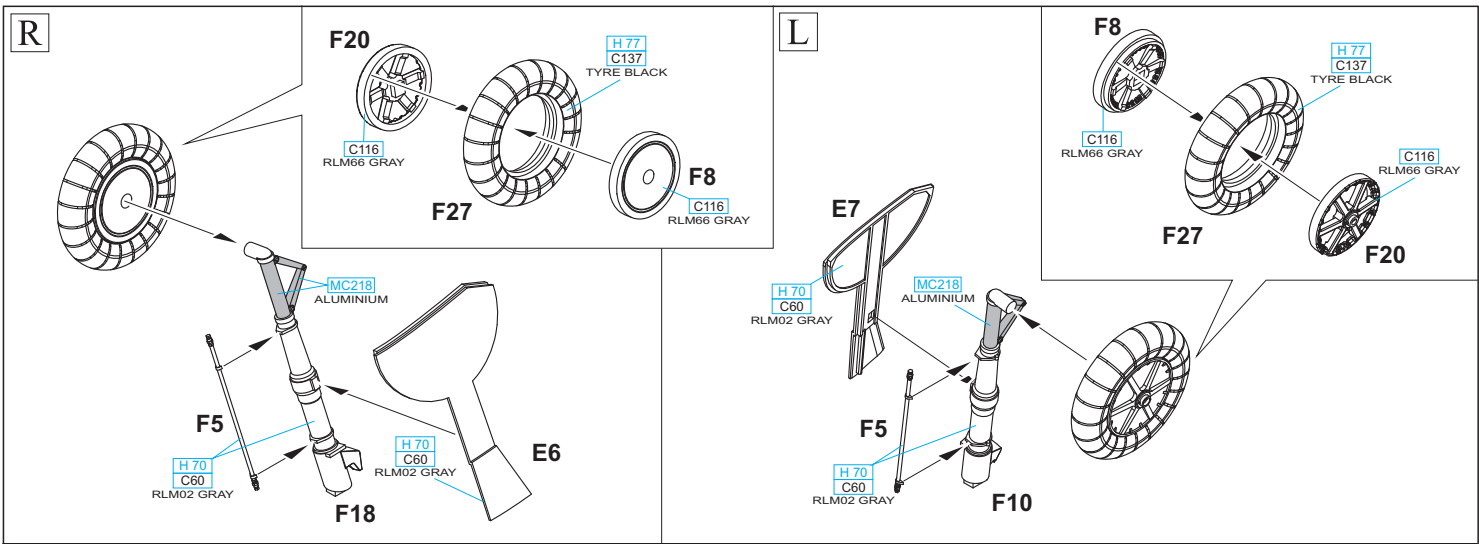



**ALTERNATIVE ASSEMBLY FOR CLOSED ENGINE COWLING.
ALTERNATIVNÍ SESTAVA PRO ZAVŘENÝ KRYT MOTORU.**

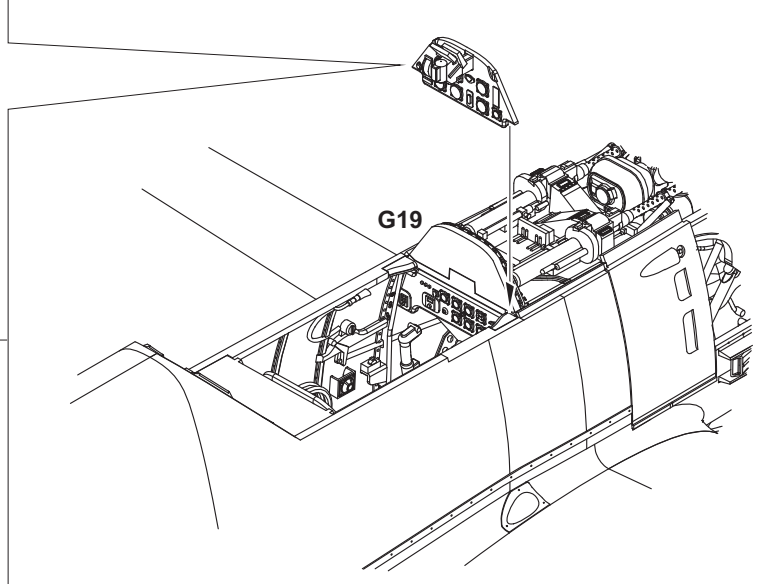
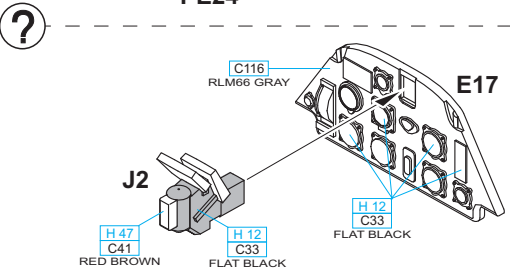
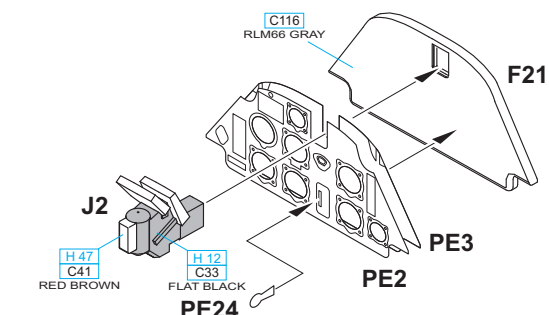
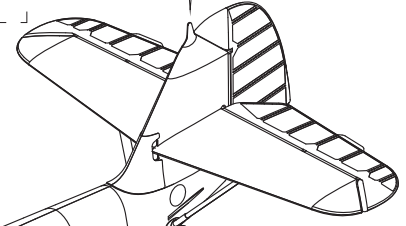
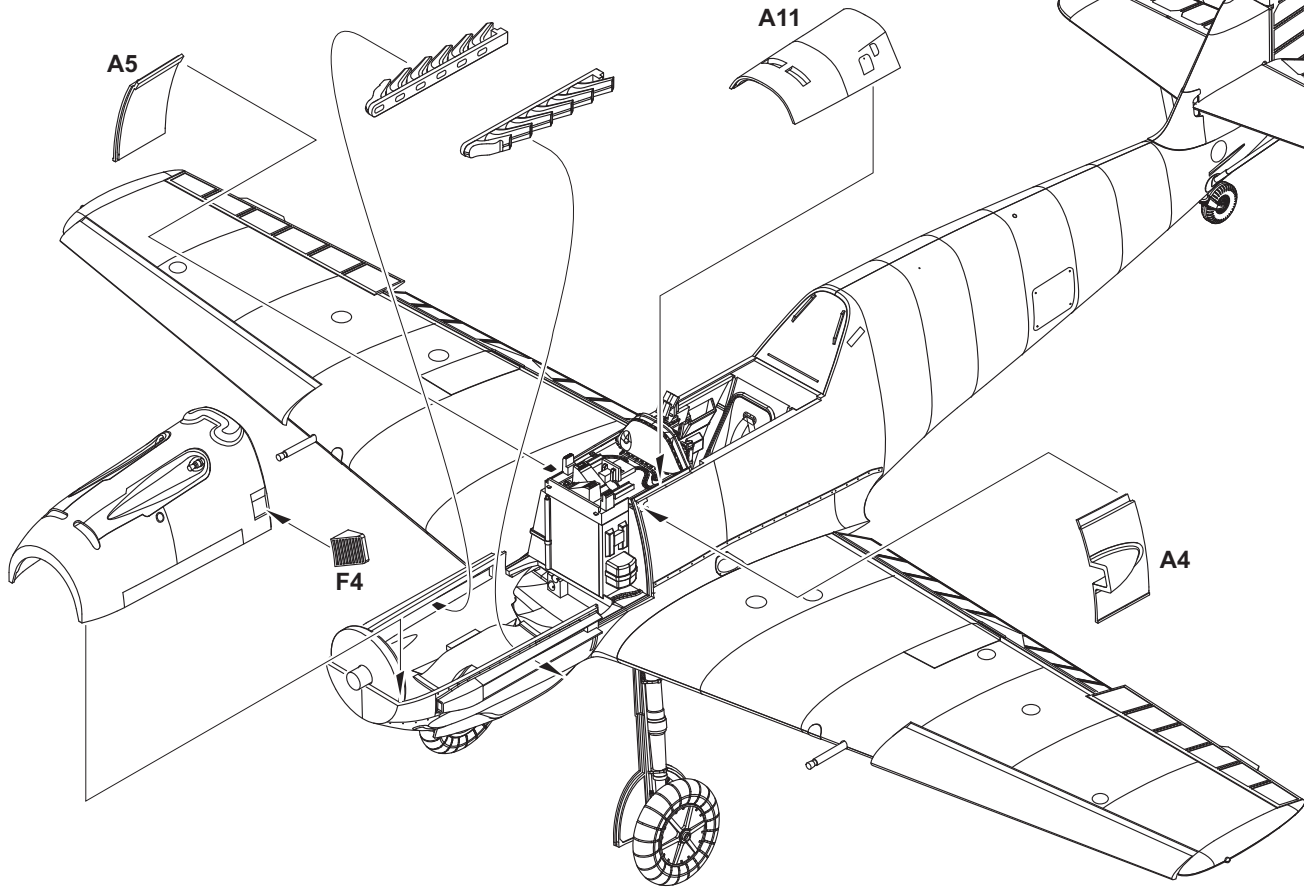
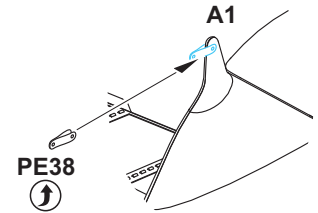
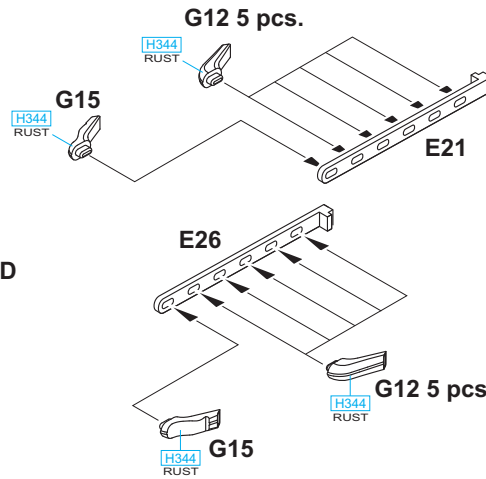
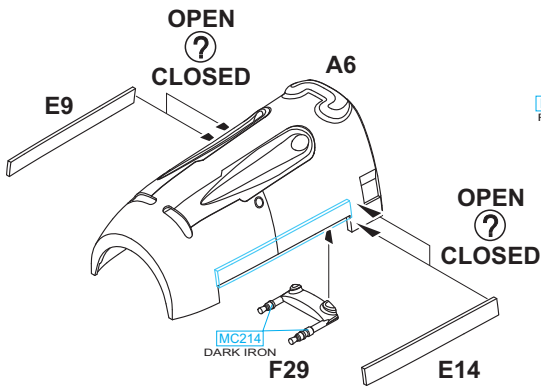

E4 - MARKING E ONLY

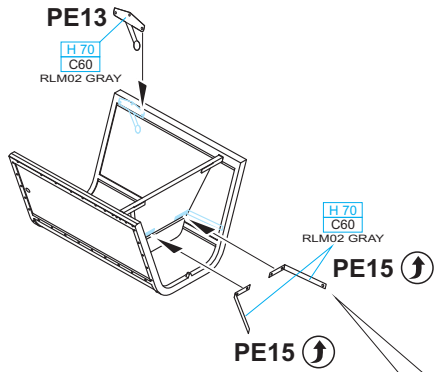
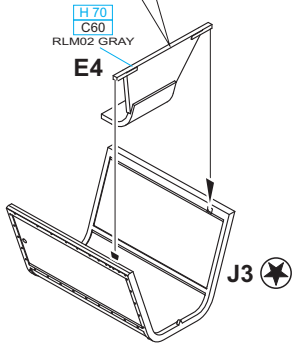

PE15 - MARKING E ONLY

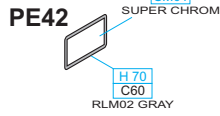
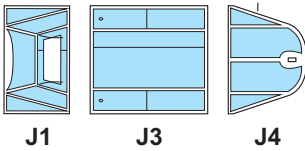
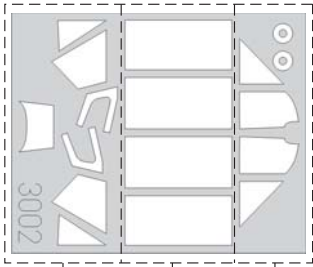
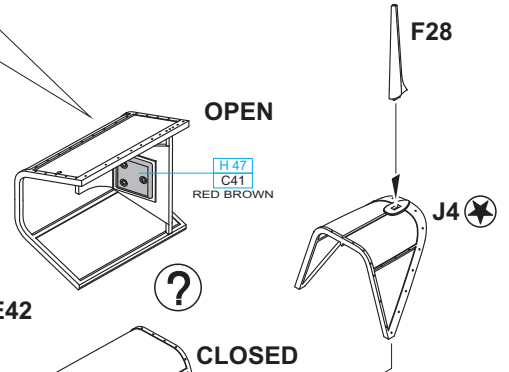

PE41, PE43 - MARKING E ONLY

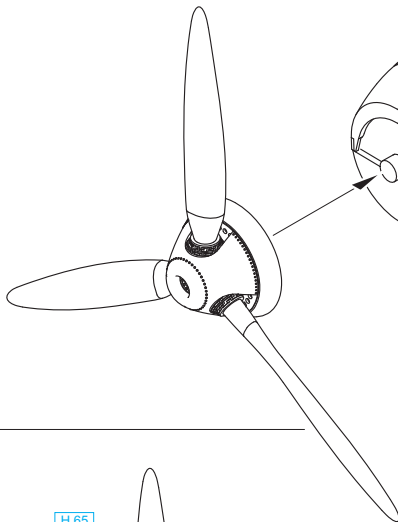
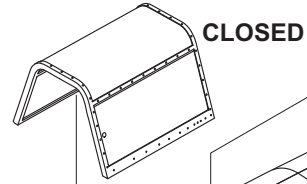
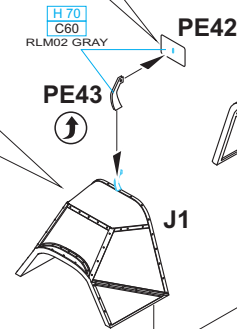
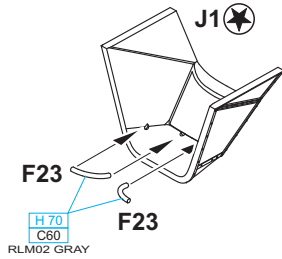

E23

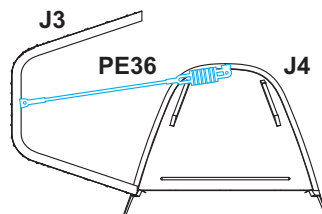
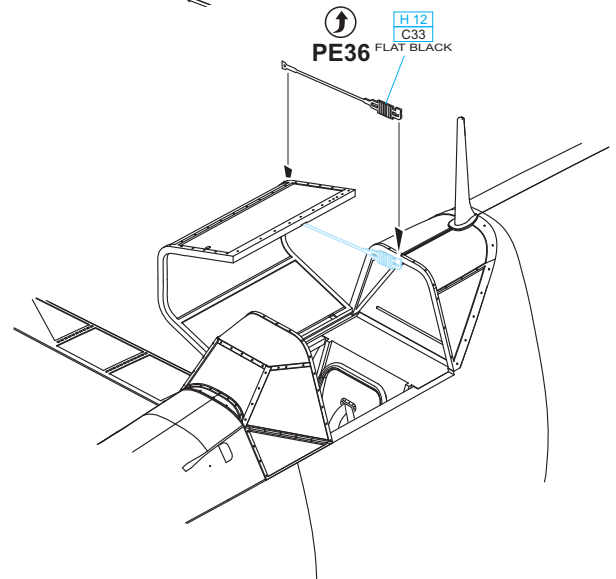
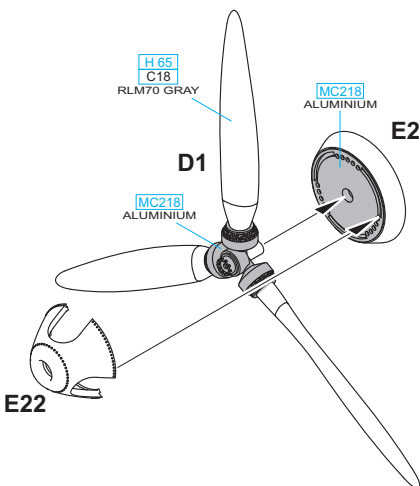

A Oblt. Josef Priller, Staffelkapitän 6./JG 51, France, Autumn 1940

Yellow '1', W.Nr. 5057, was flown by the commander of 6. Staffel JG 51, Josef Priller, and underwent several camouflage color modifications through its career. According to some sources, the initial scheme was composed of RLM 70/71/65. However, it is easier to confirm later variations, when the underside light blue was extended up the sides of the fuselage, and quite high up at that. Later, this color was subdued by the application of irregular squiggles of RLM 02 and 71. Furthermore, the upper surfaces of the wing, originally composed of broken lines, were augmented in a similar manner as the fuselage sides. This was the appearance of the aircraft in the fall of 1940, and as depicted by our profile. At the time, the aircraft also received a yellow nose section and rudder. The extent of the front end yellow coloring is up for speculation. Some sources suggest this as it appears on the boxtop of this kit, while others claim that the yellow only covered the engine cowl and spinner, as shown in this profile. The emblem of II./JG 51 'Gott strafe England!' (God punish England!) shown on the rear of the fuselage, is sprayed on without the usual white background, only with the black border around a black raven with an umbrella, symbolizing Neville Chamberlain. The Staffel marking in the form of the Ace of Hearts subsequently was used on Priller's later aircraft as a personal marking. Here, it does not yet bear the well-known 'Jutta' inscription. The kill marks denoting Priller's aerial victories on the tail in the form of vertical tabs with dates, partially obscured the Swastika. Beer lover Josef Priller attained 101 aerial victories in 1,307 operational flights between 1939 and 1945. The pictured aircraft was later inherited by another well-known Luftwaffe pilot, Hptm. Herbert Ihlefeld, who used it in 1941 in the Balkan campaign.

Additional sources: *Classic Colours: Jagdwaaffe / Attack in the West and Battle of Britain series by Eric Mombeek*

 ČESKOU VERZI TEXTU NALEZNETE NA www.eduard.com/info/photos/3002

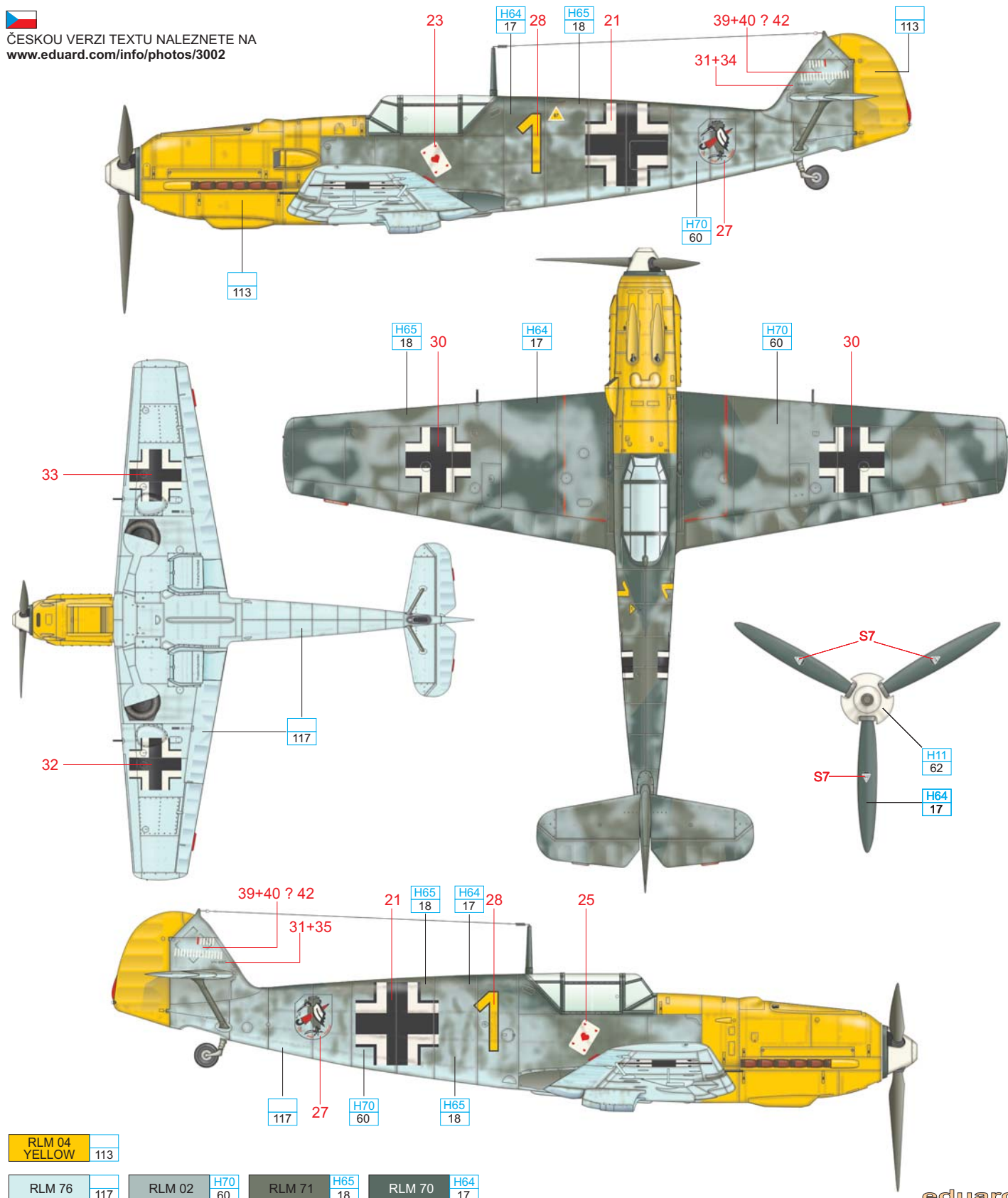

B 3./JG 51, Mannheim-Sandhofen, Winter 1939-1940

The illustrated aircraft is an example of the camouflage scheme and national marking application introduced at the end of 1939, specifically during the 'Sitzkrieg' period and during the defense of Germany against the first retaliatory raids by the RAF. The aircraft is painted in the standard scheme of RLM 70 and 71 on the upper surfaces. The paint is affected by heavy weathering and wear. The lower surfaces are in light blue, RLM 65. An interesting feature on this aircraft, and occasionally seen on others, is the very large rendering of the national marking on the wings. The fuselage Balkenkreuz also has a more slender centre cross segment. The Totenhand marking below the cockpit is the 3./JG 51 unit insignia, while the Kitzbuheler Gams marking, which was used by I./JG 51 from its beginnings, was a reminder of the influx of Austrian pilots to the unit in 1938, at a time when it carried the markings of I./JG 233.

Additional sources: *Classic Colours: Jagdwaffe / Attack in the West and Battle of Britain* series by Eric Mombeek



ČESKOU VERZI TEXTU NALEZNETE NA
www.eduard.com/info/photos/3002

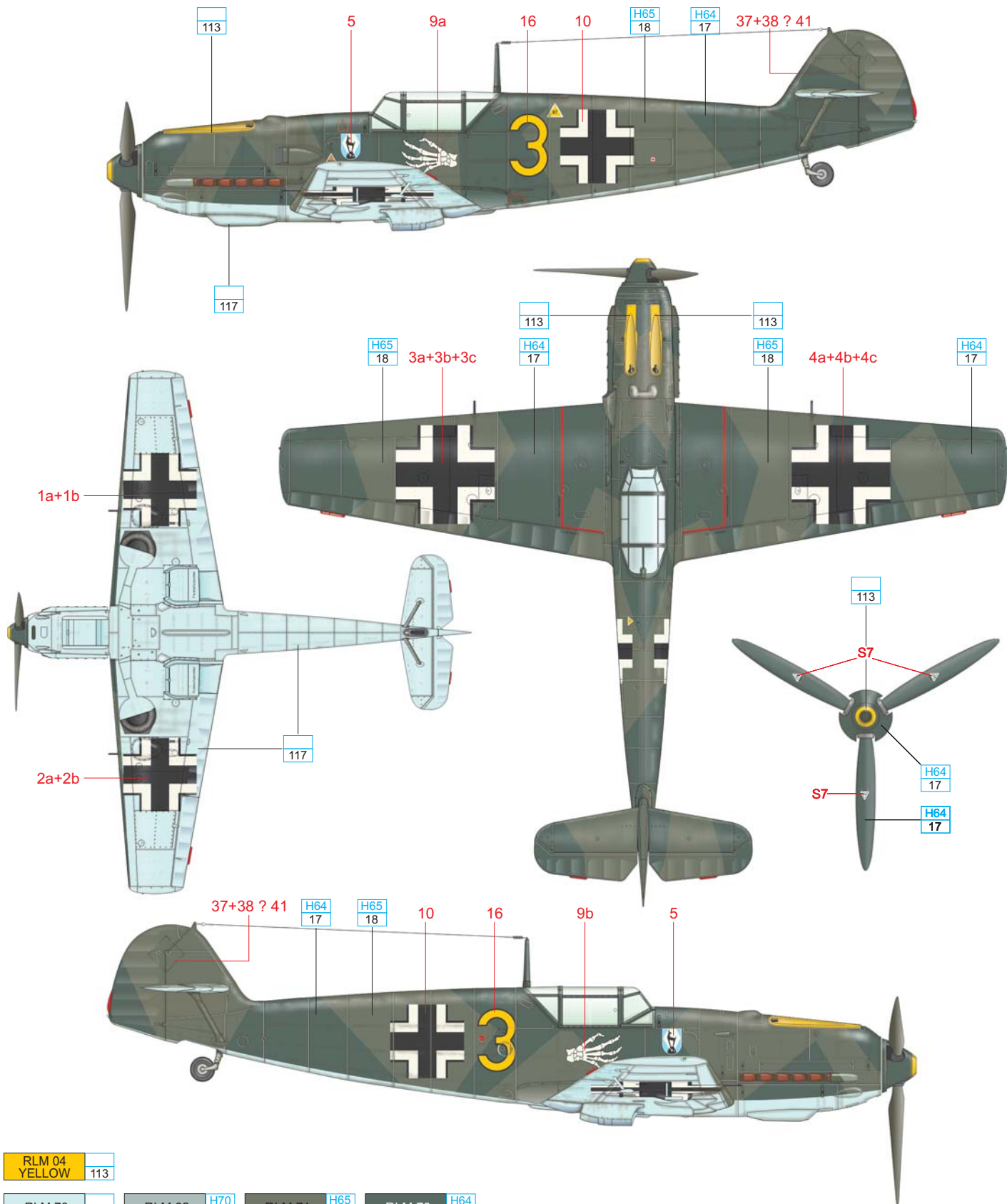

RLM 04
 YELLOW 113

RLM 76 117

RLM 02 H70 60

RLM 71 H65 18

RLM 70 H64 17

C 1./JG 2, Bassenheim, Germany, May 1940

The illustrated White '7' flew in the spring of 1940 with Staffel JG 2 under the command of Spanish Civil War veteran Oblt. Otto Bertram. The aircraft carries the standard period camouflage scheme consisting of RLM 02/71 on the upper surfaces. The lower surface light blue RLM 65 extended quite high up the fuselage sides. An oddity on this aircraft is the application of older national markings on this newer scheme, including the smaller fuselage crosses with very thin border segments and the application of the Swastika such that it covered both the rudder and the fin. The emblem of JG 2 Richthofen appeared on both sides of the fuselage under the cockpit. Similarly, the Staffel marking of a leashed dog 'Bonzo' appeared on both sides, and was developed by Otto Bertram. The emblem of JG 2 Richthofen appeared on both sides of the fuselage under the cockpit. Similarly, the Staffel marking of a leashed dog 'Bonzo' appeared on both sides, and was developed by Otto Bertram. The emblem of JG 2 Richthofen appeared on both sides of the fuselage under the cockpit. Similarly, the Staffel marking of a leashed dog 'Bonzo' appeared on both sides, and was developed by Otto Bertram. The emblem of JG 2 Richthofen appeared on both sides of the fuselage under the cockpit. Similarly, the Staffel marking of a leashed dog 'Bonzo' appeared on both sides, and was developed by Otto Bertram.

Additional sources: *Classic Colours: Jagdwaffe / Attack in the West and Battle of Britain series by Eric Mombeek*

ČESKOU VERZI TEXTU NALEZNETE NA
www.eduard.com/info/photos/3002

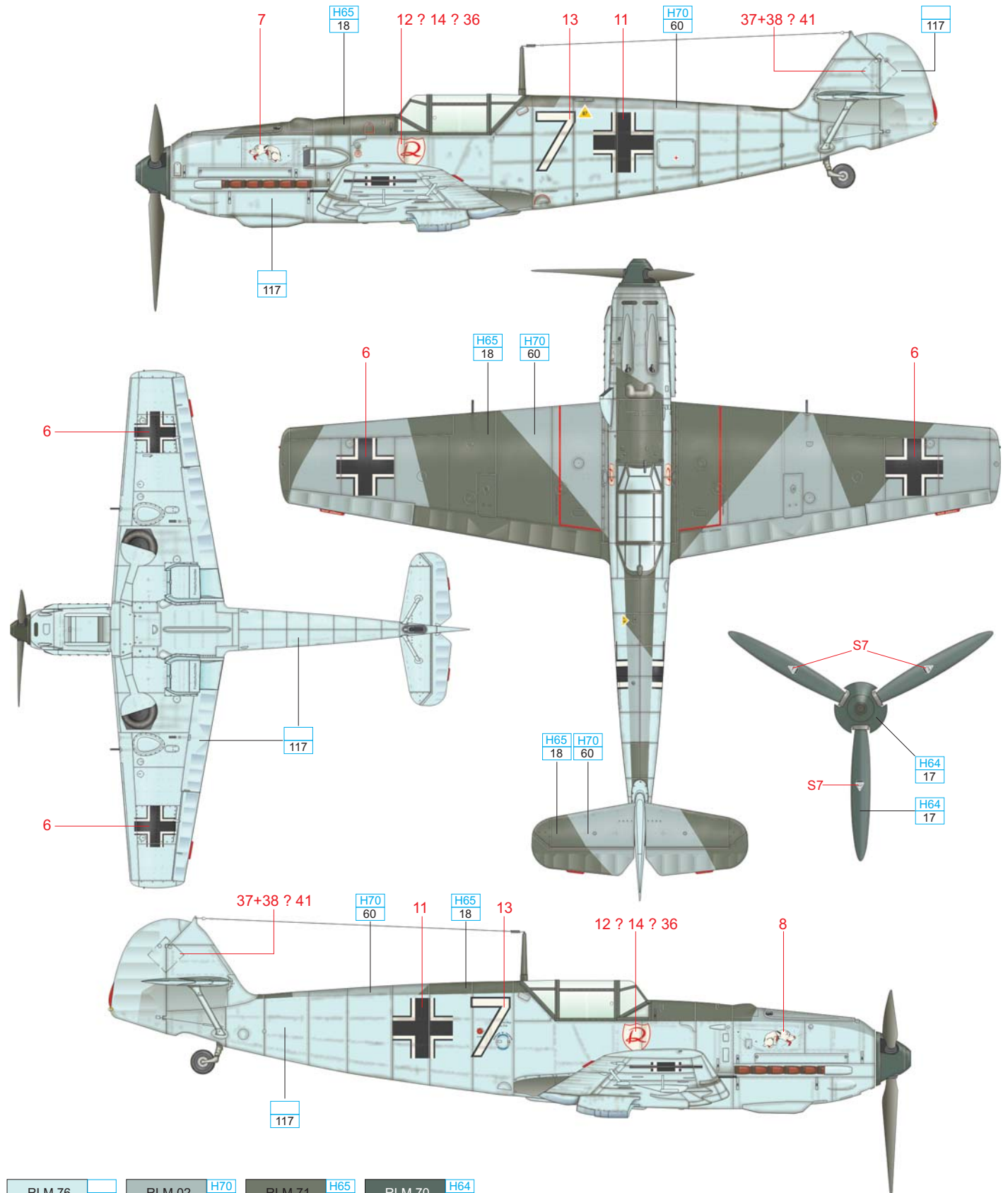

RLM 76	117	RLM 02	H70 60	RLM 71	H65 18	RLM 70	H64 17
--------	-----	--------	-----------	--------	-----------	--------	-----------

D Obstlt. Hans-Hugo Witt, Geschwaderkommodore JG 26, Dortmund, Germany, April 1940

This aircraft, which carried an unusual camouflage scheme for the noted period, was flown by the CO of JG 26, Obstlt. Hans-Hugo Witt in April, 1940. Upper surfaces were composed of fields of RLM 02 and 71, while the bottom carried the standard RLM 65. The Geschwaderkommodor tactical marking was supplemented by a simplified version of the 'Schlageter' emblem, the unit marking of JG 26. The mounted rider was marking of Stab/JG 26 and was found exclusively on the left side of the fuselage. Jagdgeschwader 26 participated in the Battle of France during this timeframe. Hans-Hugo led the unit until June 23, 1940, when he left at the age of 39 to take on several command functions in the Luftwaffe leadership. Witt is also known for being a survivor of the ill-fated Hindenburg flight on May 6, 1937.

Additional sources: *Classic Colours: Jagdwaffe / Attack in the West and Battle of Britain series by Eric Mombeek*



ČESKOU VERZI TEXTU NALEZNETE NA
www.eduard.com/info/photos/3002

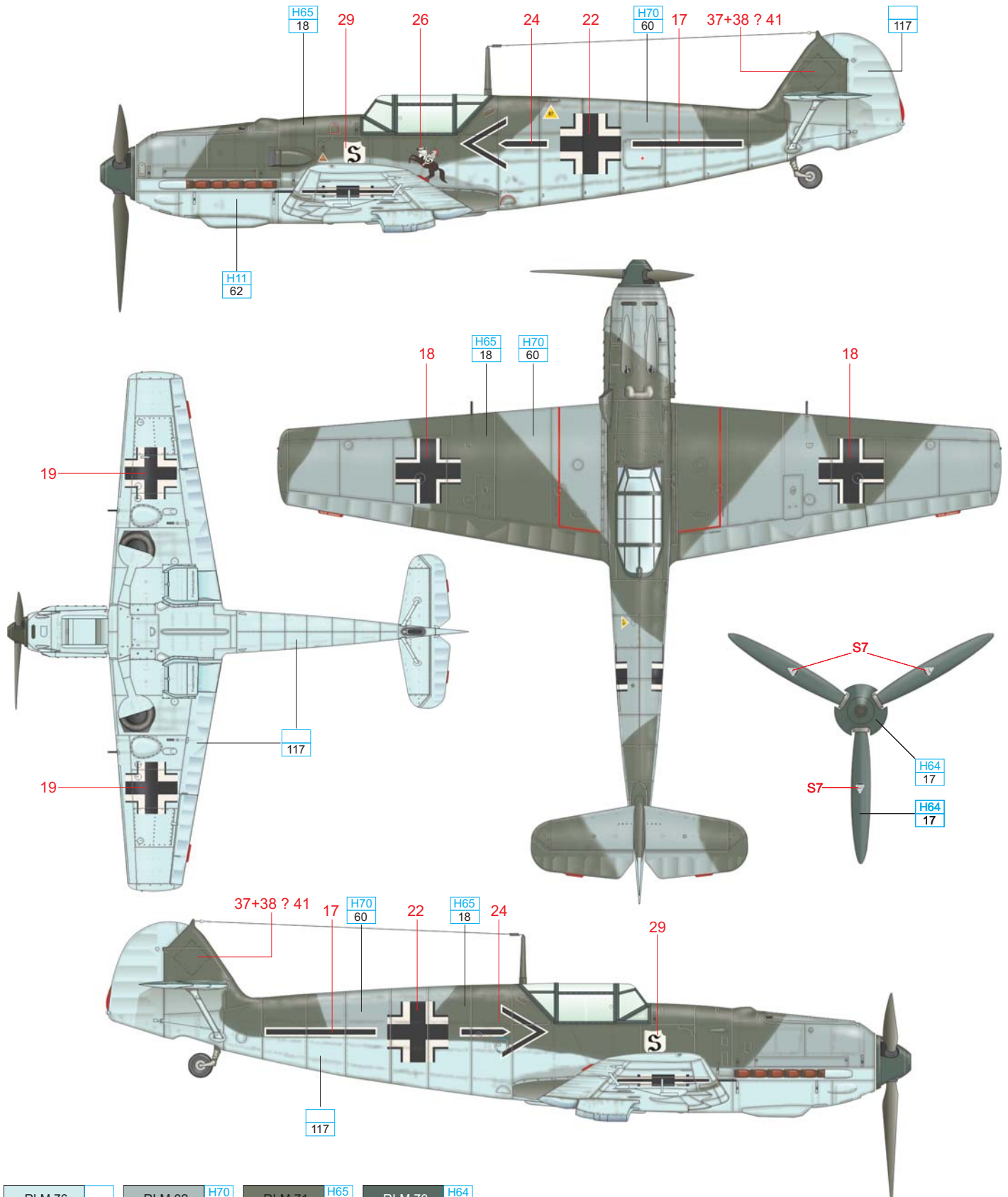

RLM 76	117	RLM 02	H70	60	RLM 71	H65	18	RLM 70	H64	17
--------	-----	--------	-----	----	--------	-----	----	--------	-----	----

E Uffz. Karl Wolff, 3./JG 52, Pihen/Calais, France, August 1940

A very attractive scheme was carried by Bf 109E-3 White '15', with which Uffz. Karl Wolff crashed on landing on August 30, 1940. It carried the standard scheme of RLM 02/71/65, and the light blue 65 extended up the fuselage sides. The light blue, which also wrapped around the leading edges of the wings, was subdued with overspray of colors used on the upper surfaces. Furthermore, the aircraft received white paint on surfaces such as the nose, rudder and wingtips, used first and foremost as quick identification features. The I. Gruppe JG 52 unit emblem appeared on the nose of the plane. A month after his hard landing in White '15', Uffz. Wolff was shot down and taken prisoner.

Jagdgeschwader 52 became the Luftwaffe's most successful fighter unit mainly due to its operations over the Eastern Front. However, its successes began during the Battle of France, and later, the Battle of Britain. By the end of 1940, the unit's pilots had already racked up 177 kills. On the other hand, losses were quite high as well. Just during the Battle of Britain, the unit lost 53 pilots. The unit was also odd in that its equipment over the course of the war was composed exclusively of Bf 109s.

Additional sources: *Classic Colours: Jagdwaaffe / Attack in the West and Battle of Britain series by Eric Mombeek*

 ČESKOU VERZI TEXTU NALEZNETE NA www.eduard.com/info/photos/3002

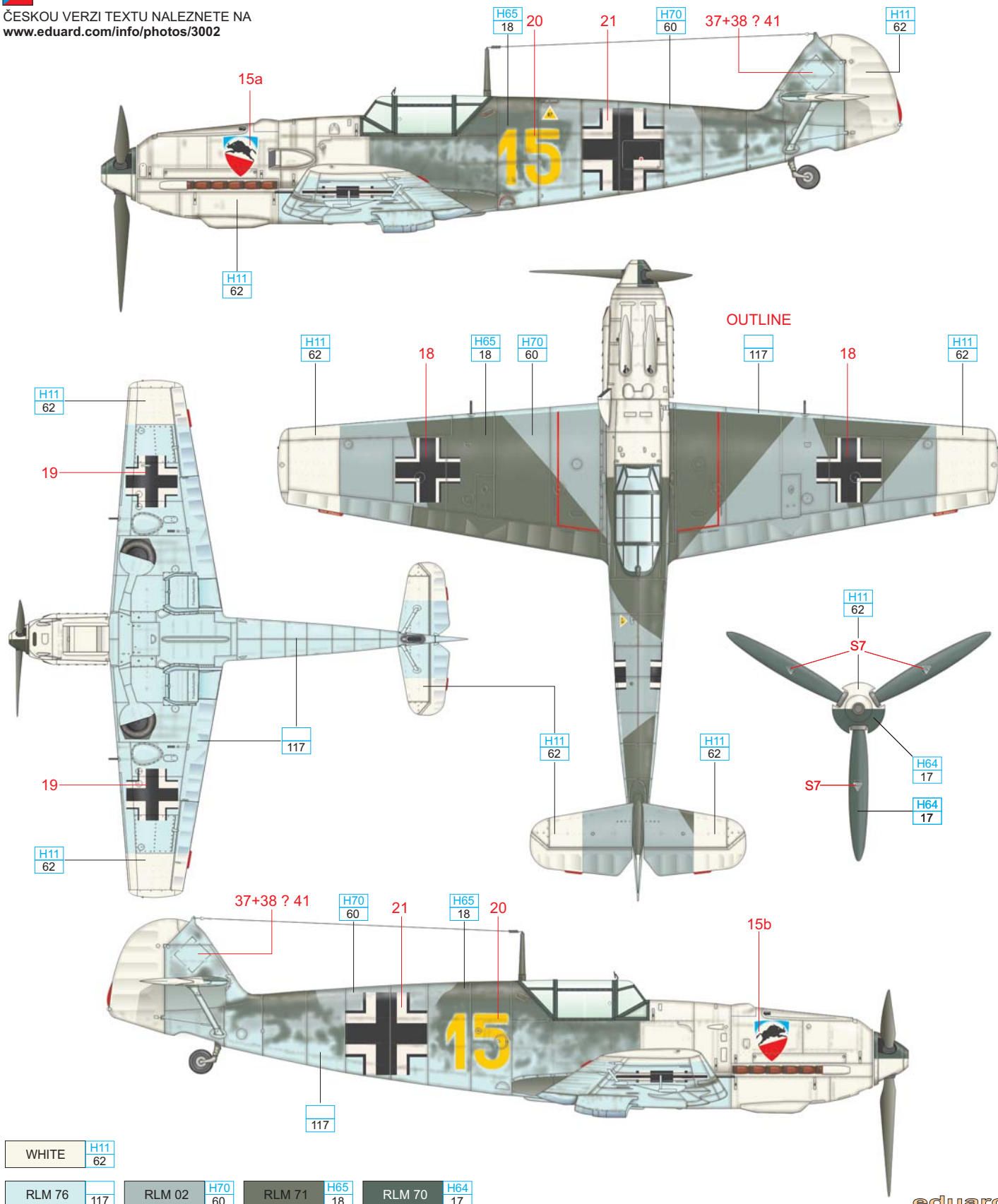

WHITE H11
62

RLM 76 117

RLM 02 H70
60

RLM 71 H65
18

RLM 70 H64
17

Bf 109E-3 STENCIL DATA

