



BMPT Terminator

eduard

36 304

detail set for 1/35 MENG TS-10 kit • sada detailů pro stavebnici 1/35 MENG TS-10

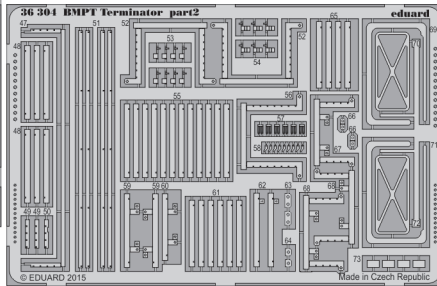
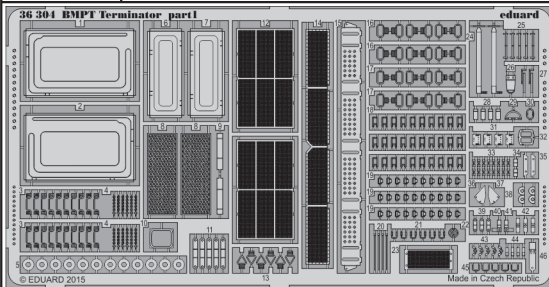

- ★ APPLY EXPRESS MASK AND PAINT BEFORE GLUING
POUŽIT EXPRESS MASK NABARVIT PŘED SLEPENÍM
- ◐ SYMMETRICAL ASSEMBLY
SYMETRICKÁ MONTÁŽ
- REMOVE
ODSTRANIT
- ▨ GRIND
OBROUSIT
- ⊘ DRILL HOLE
VRTAT OTVOR
- 1 COLORED ETCHED PARTS
LEPTANÉ BAREVNÉ DÍLY
- 1 ETCHED PARTS
LEPTANÉ NEBAREVNÉ DÍLY
- 1 ORIGINAL KIT PARTS
PŮVODNÍ DÍLY STAVEBNICE
- ↪ BEND
OHNOUT
- ? OPTION
VOLBA
- Ⓜ REPLACE
NAHRADIT
- ↺ REVERSE SIDE
OTOČIT

ORIGINAL KIT PARTS
PŮVODNÍ DÍLY STAVEBNICE

PHOTO-ETCHED PARTS
LEPTANÉ DÍLY

PARTS TO BE REMOVED
DÍLY K ODSTRANĚNÍ

FILL
TMELIT

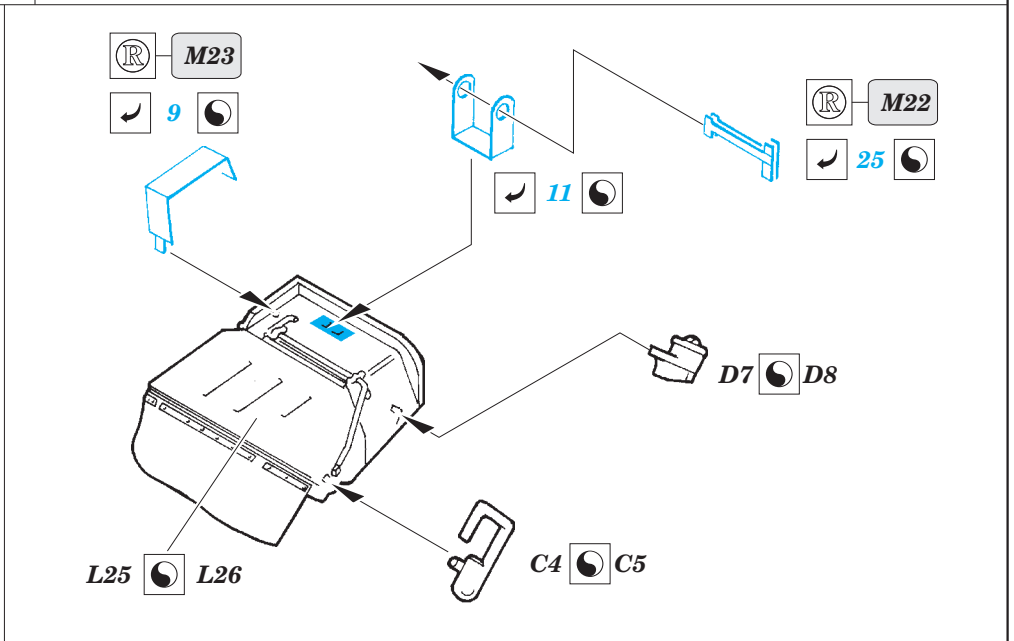
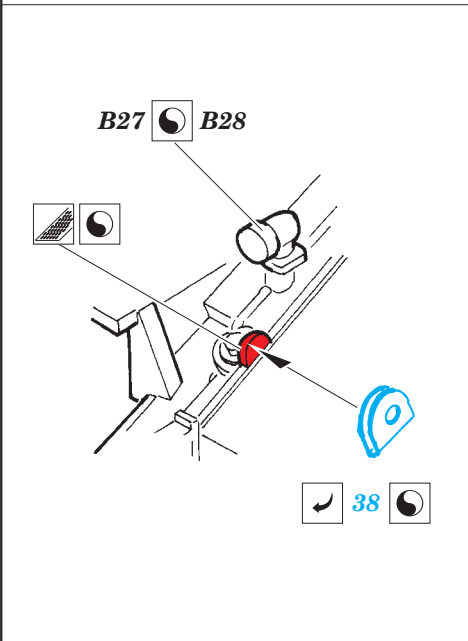
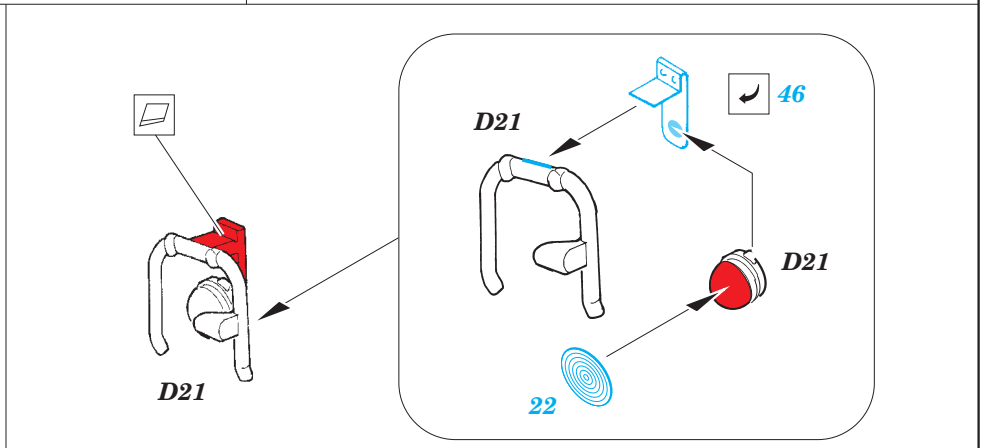
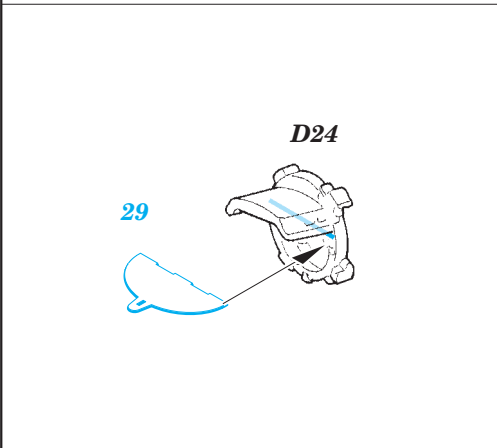
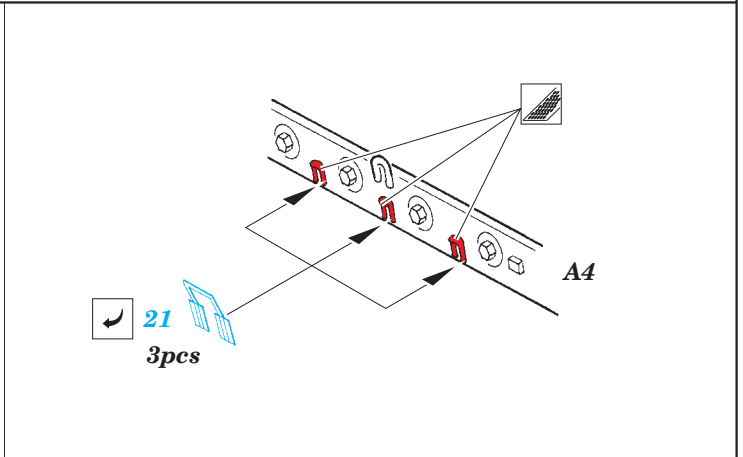
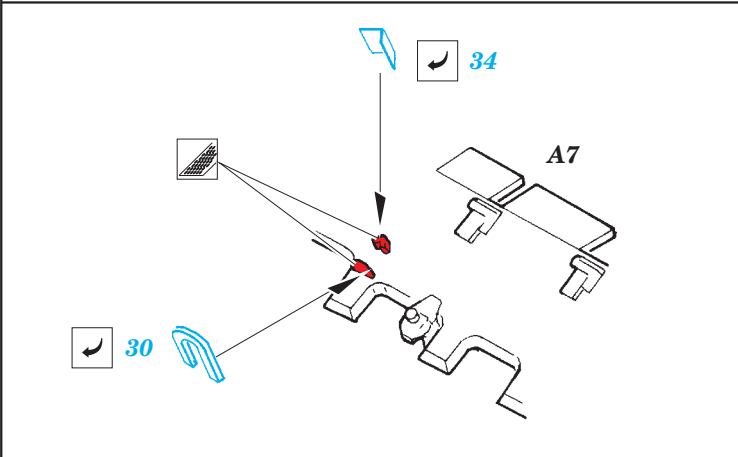

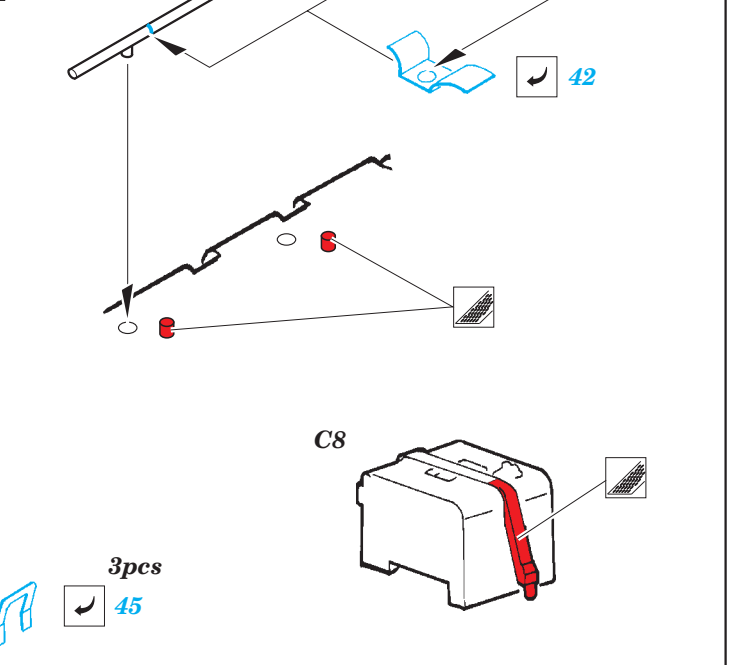
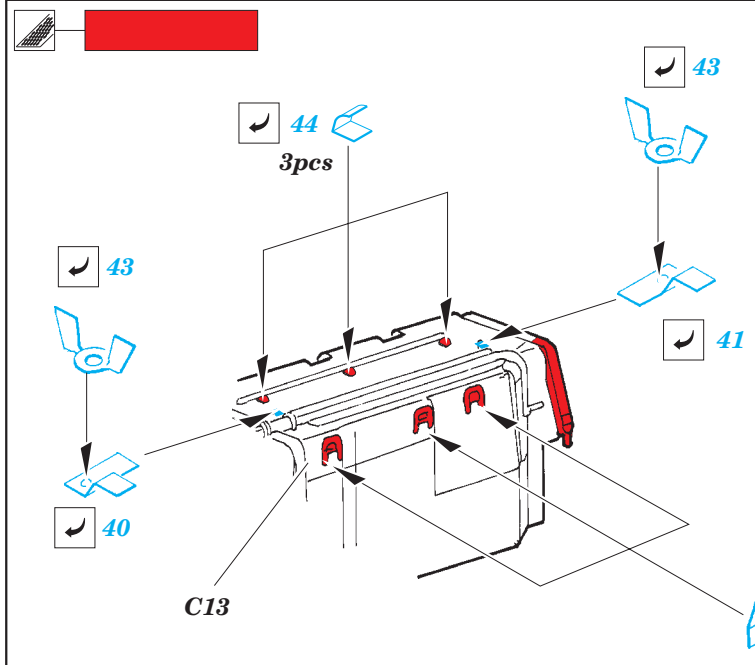
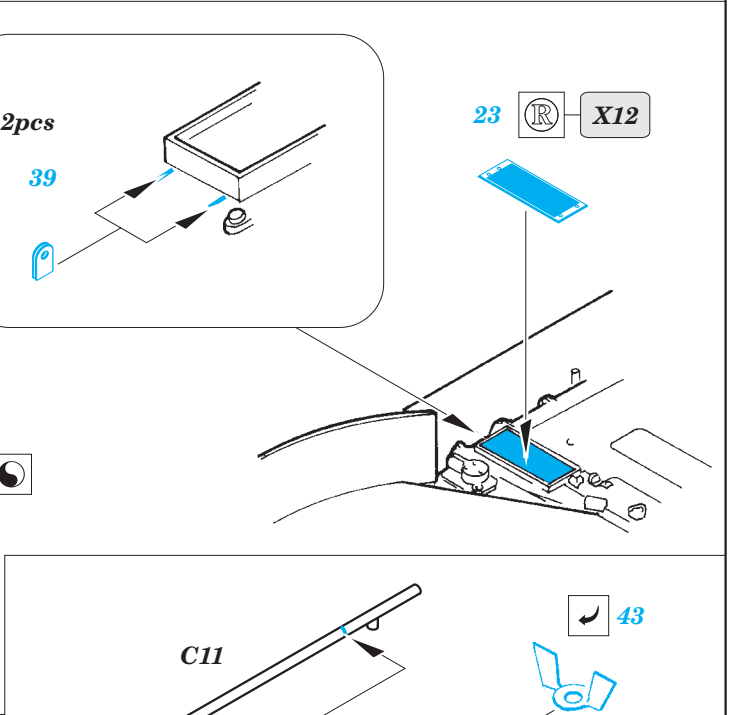
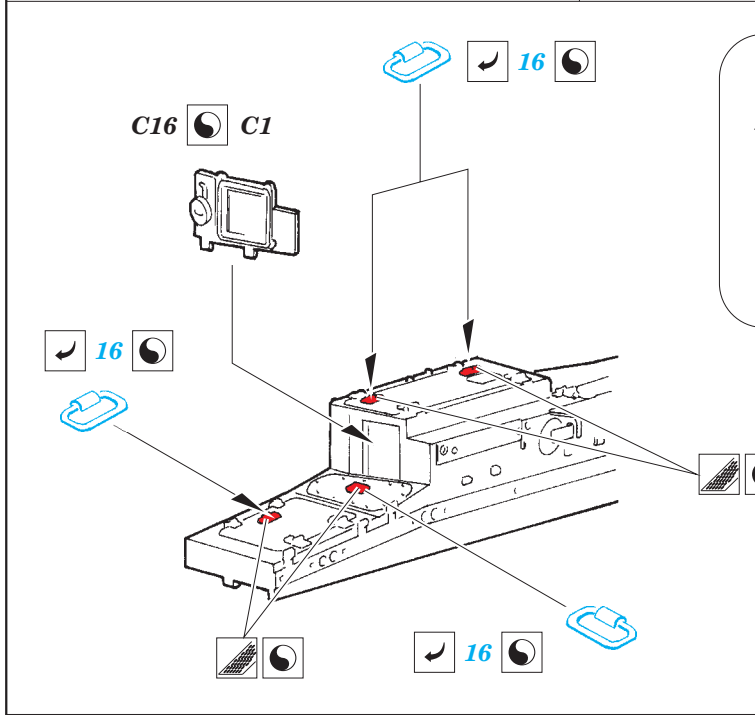
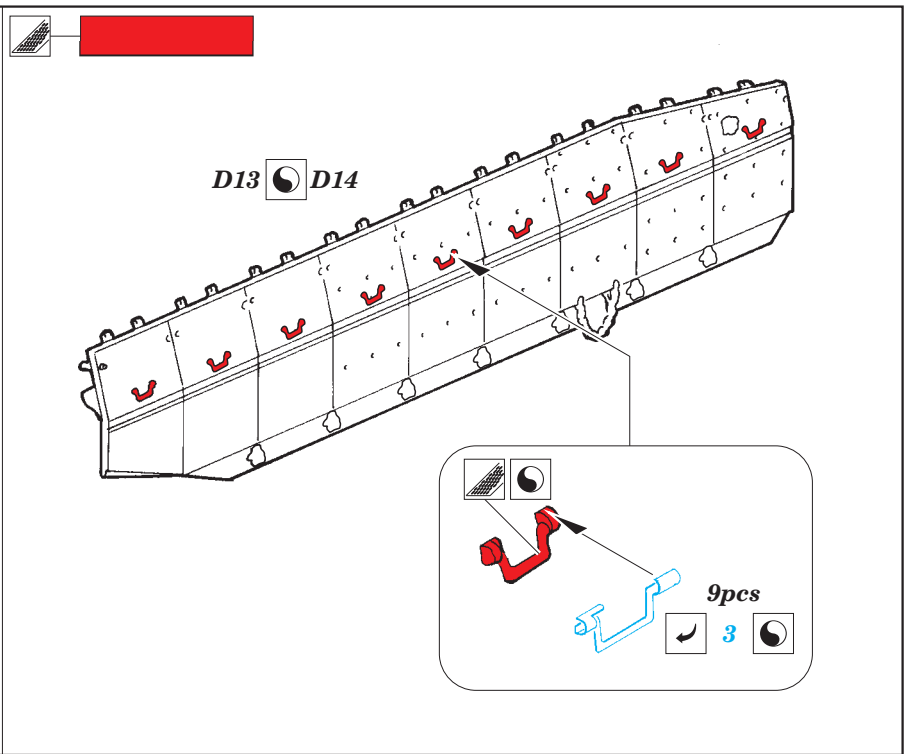
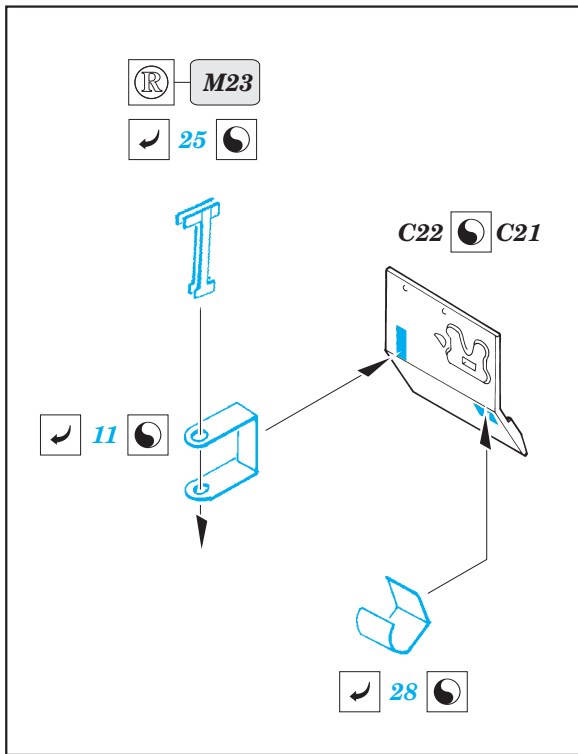

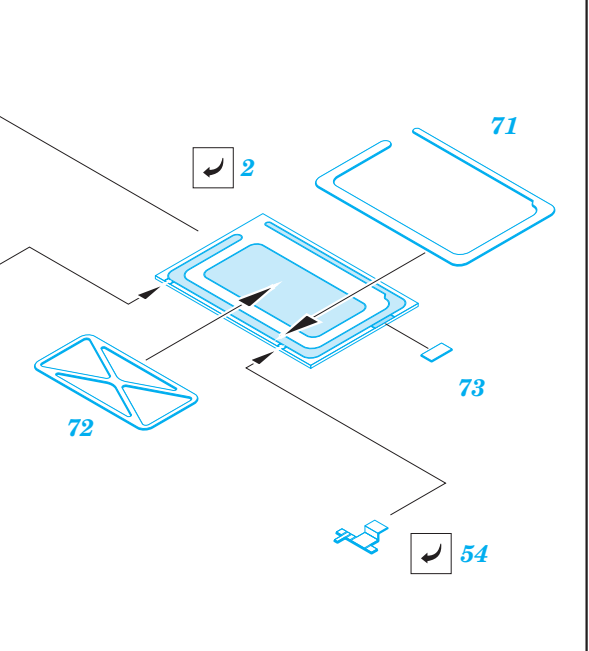
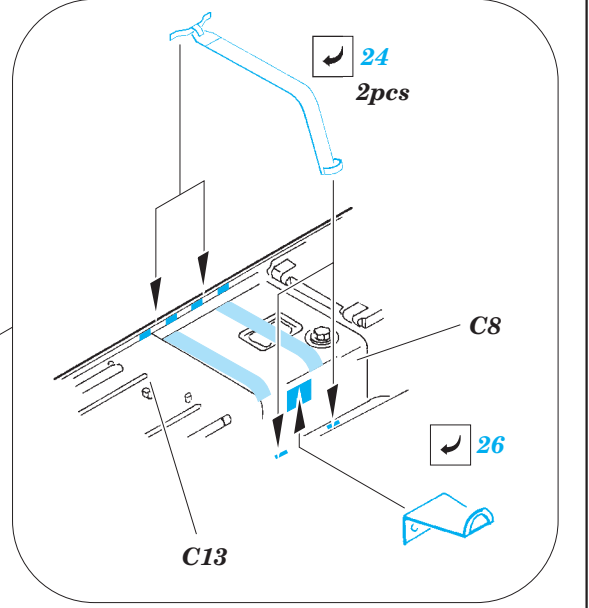
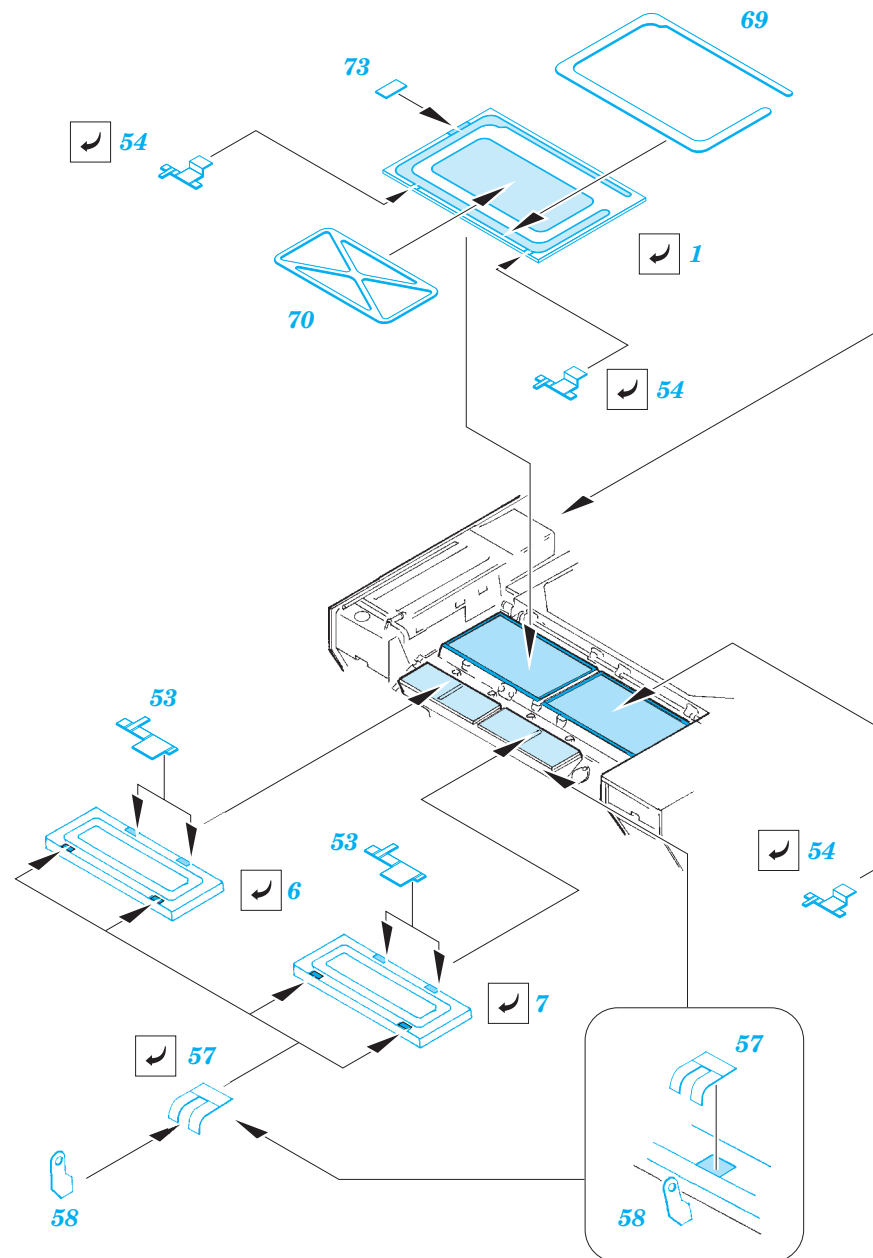
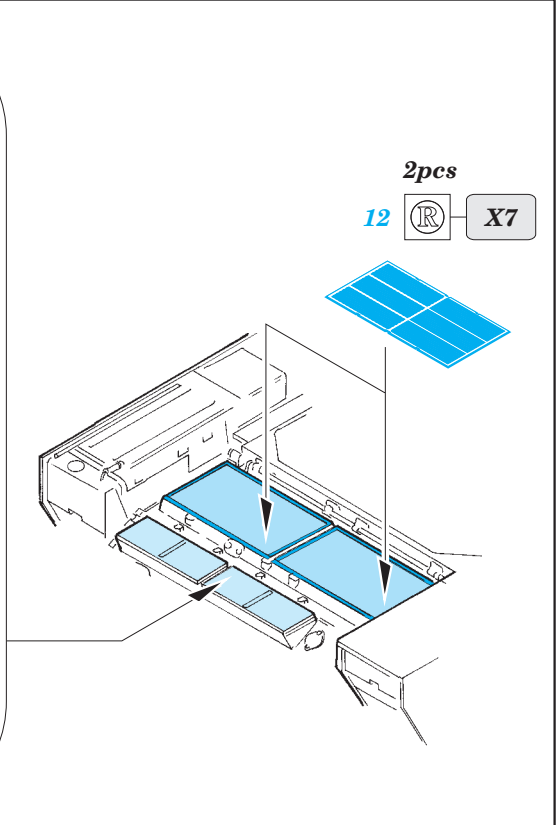
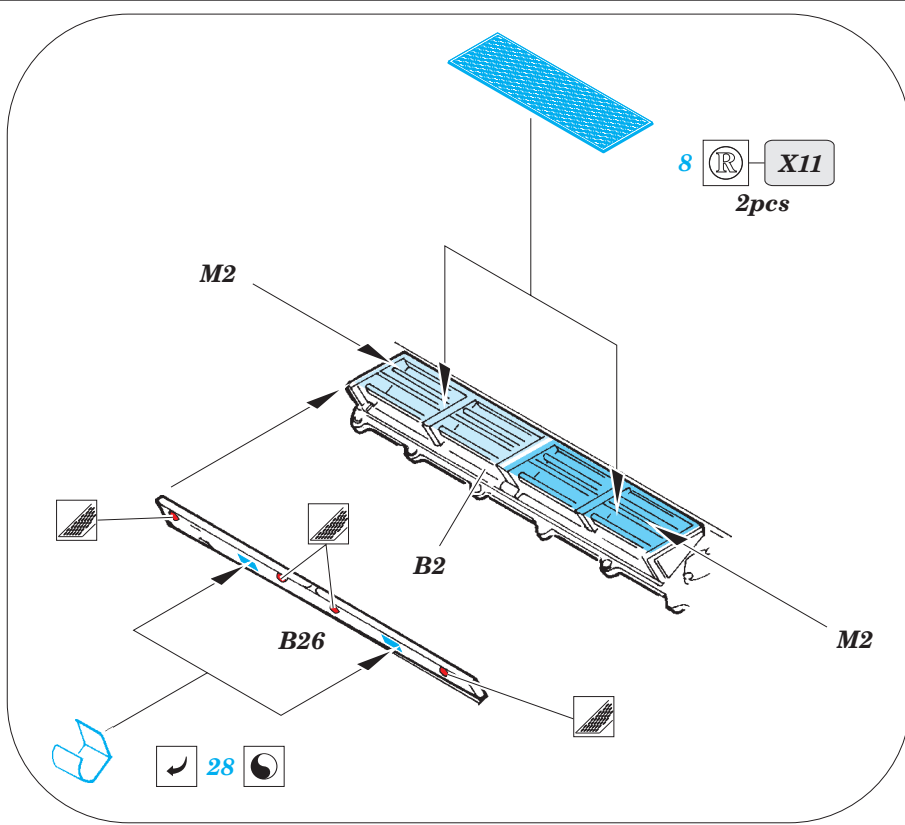

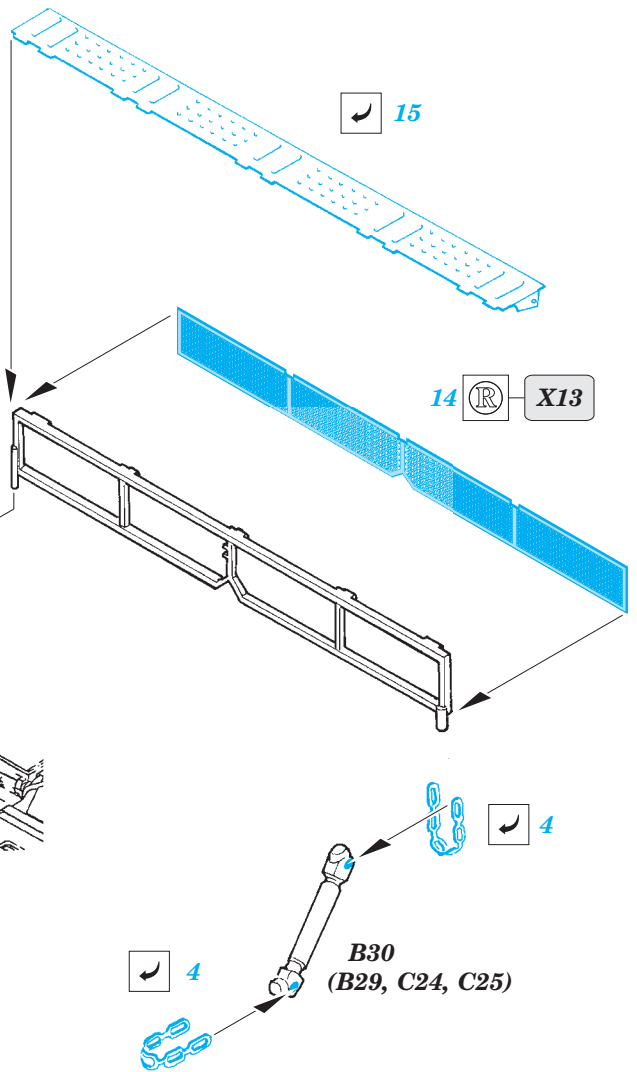
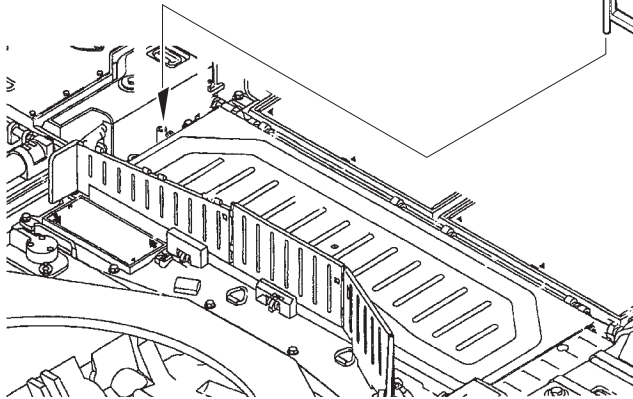
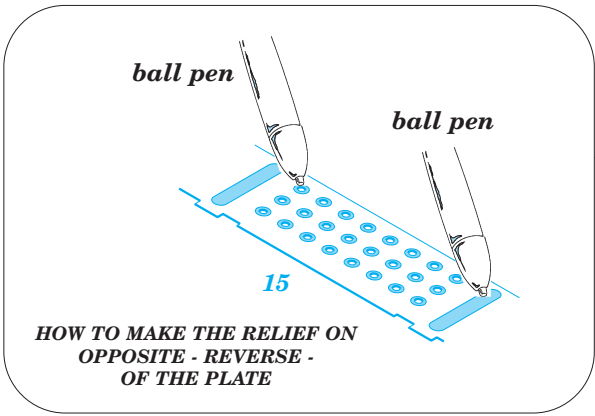

step #1

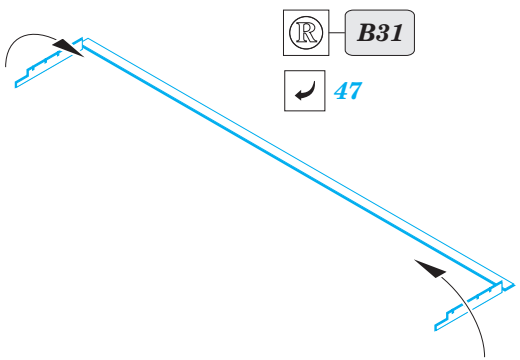

step #2

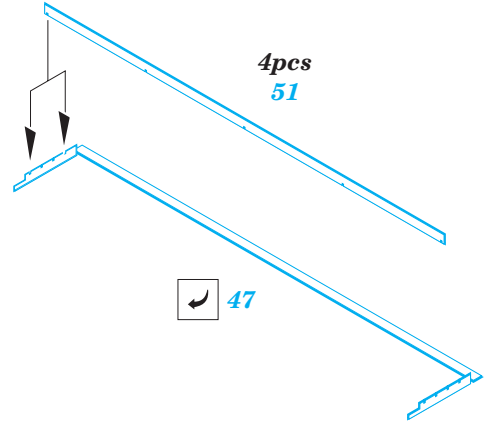

step #3

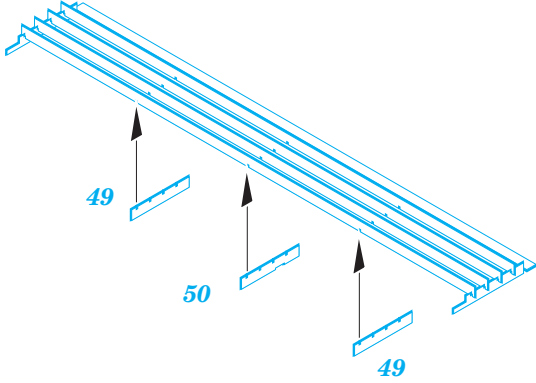

step #4

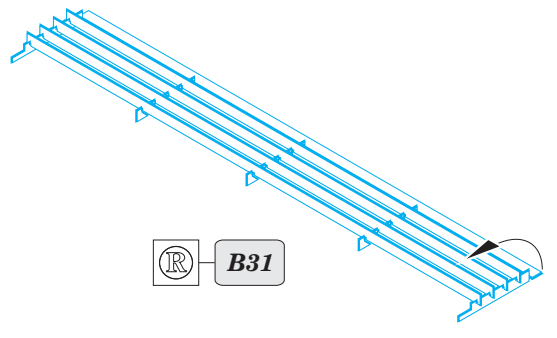

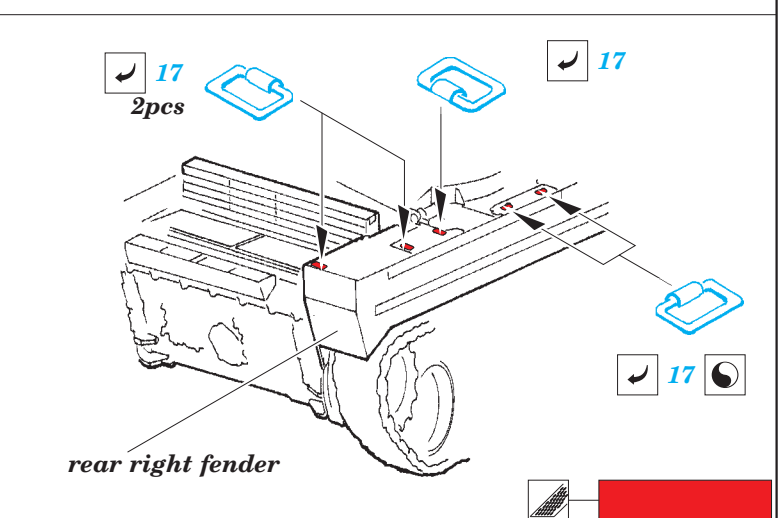
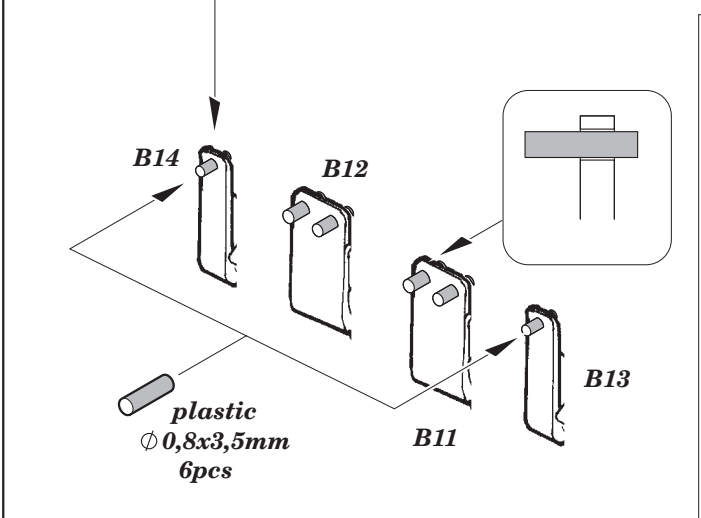
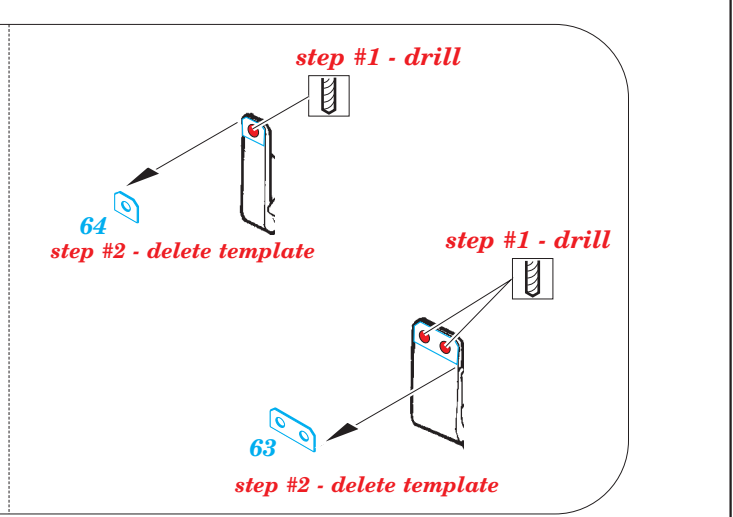
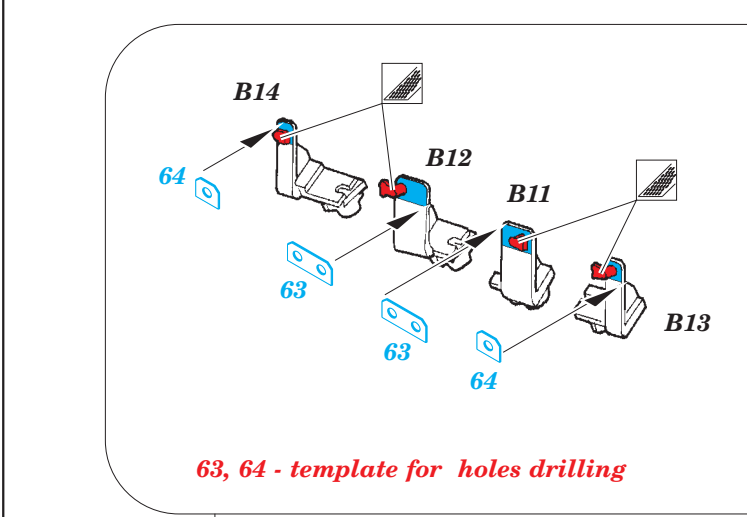
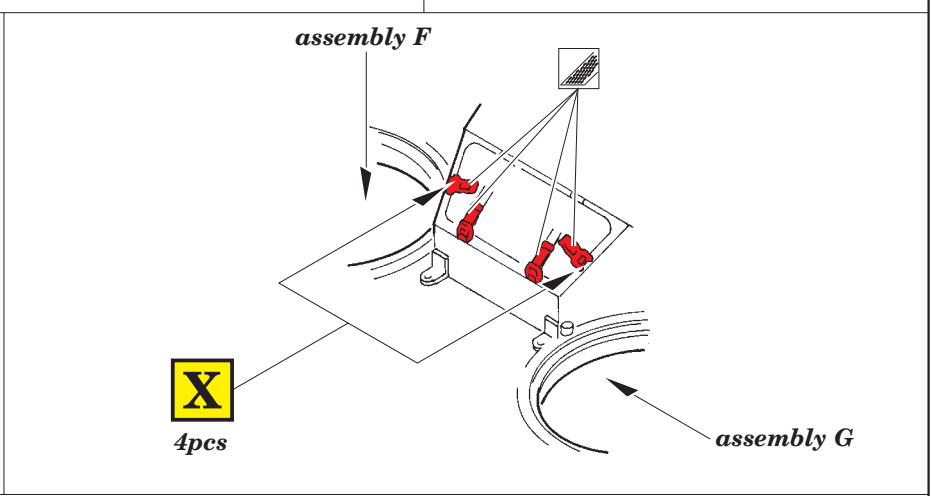
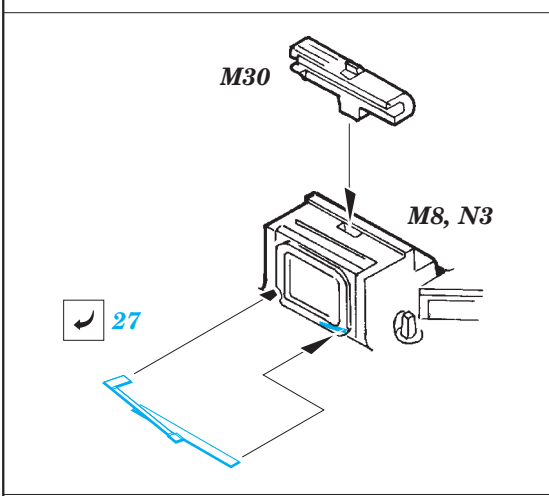
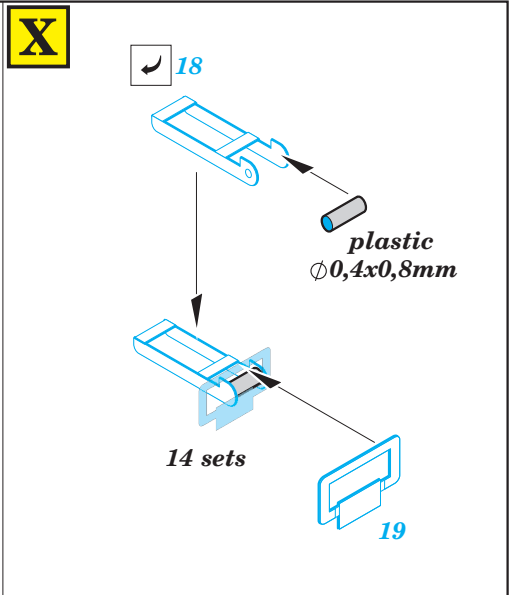
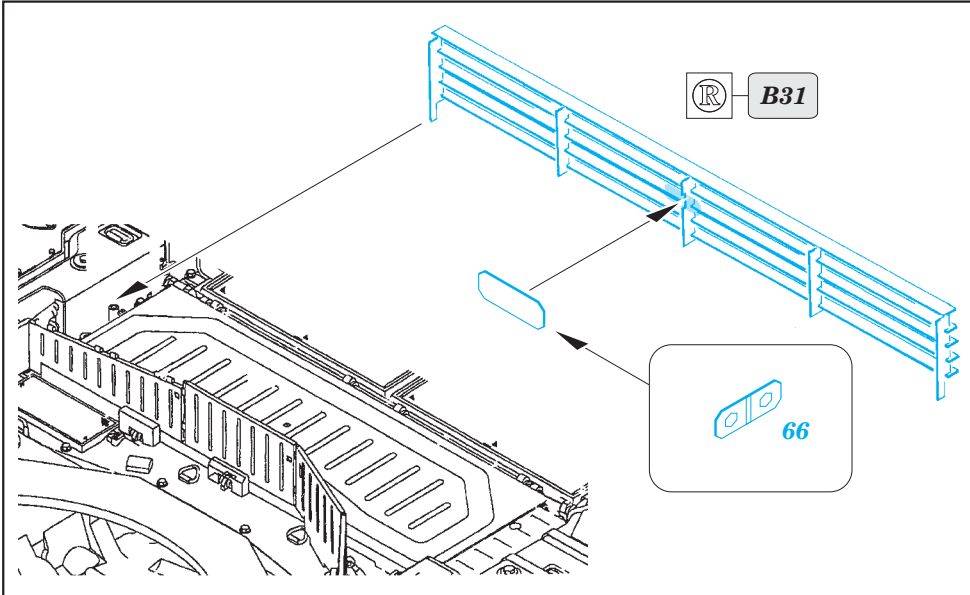

A

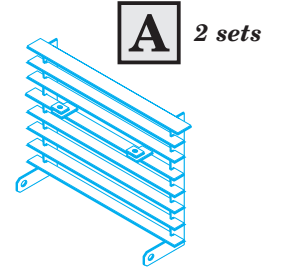
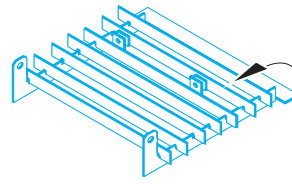
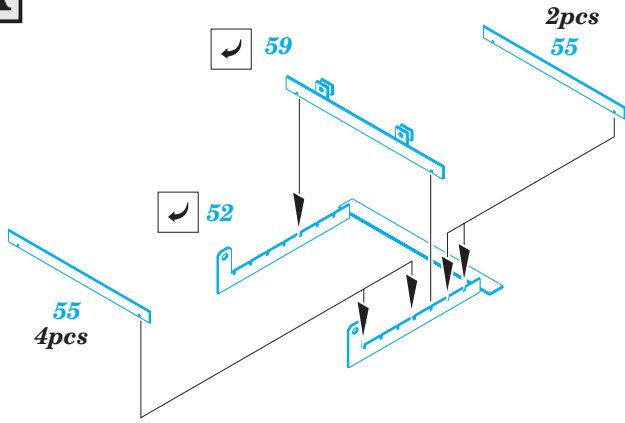

B

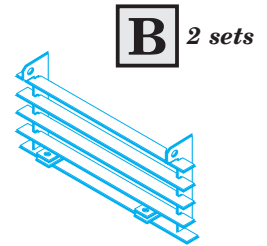
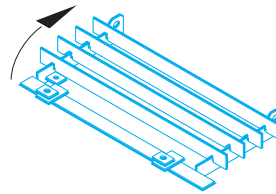
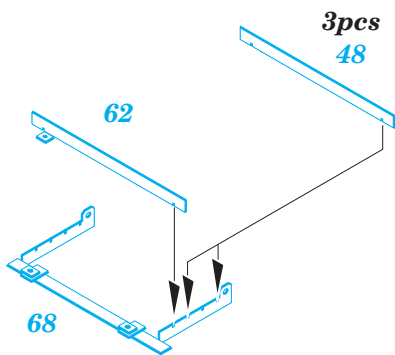

C

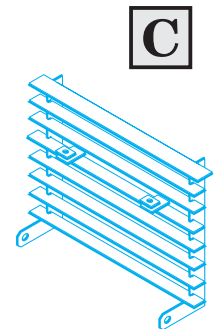
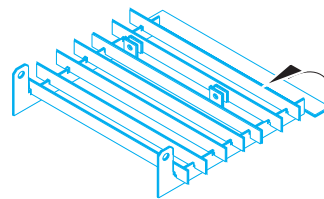
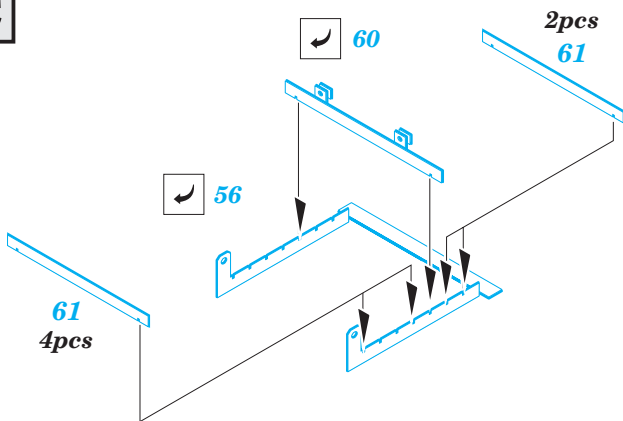

D

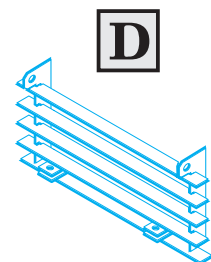
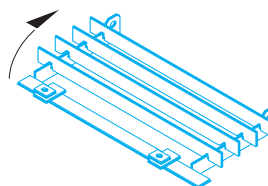
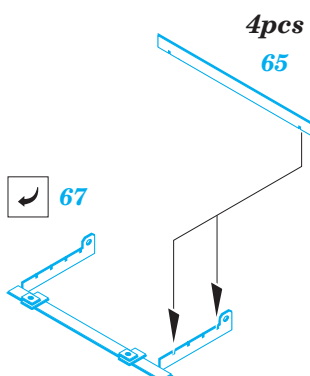

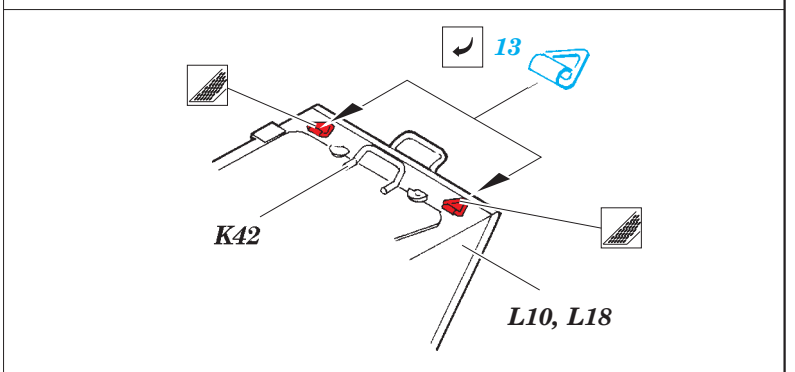
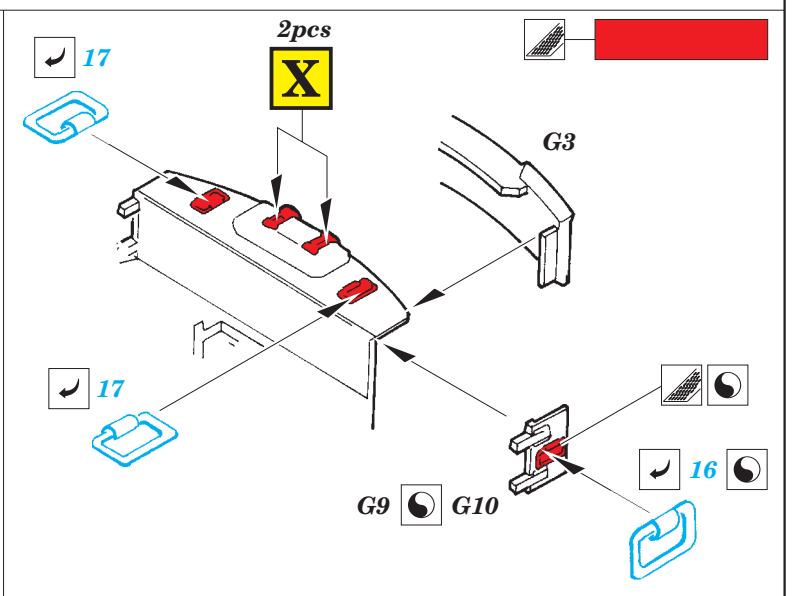
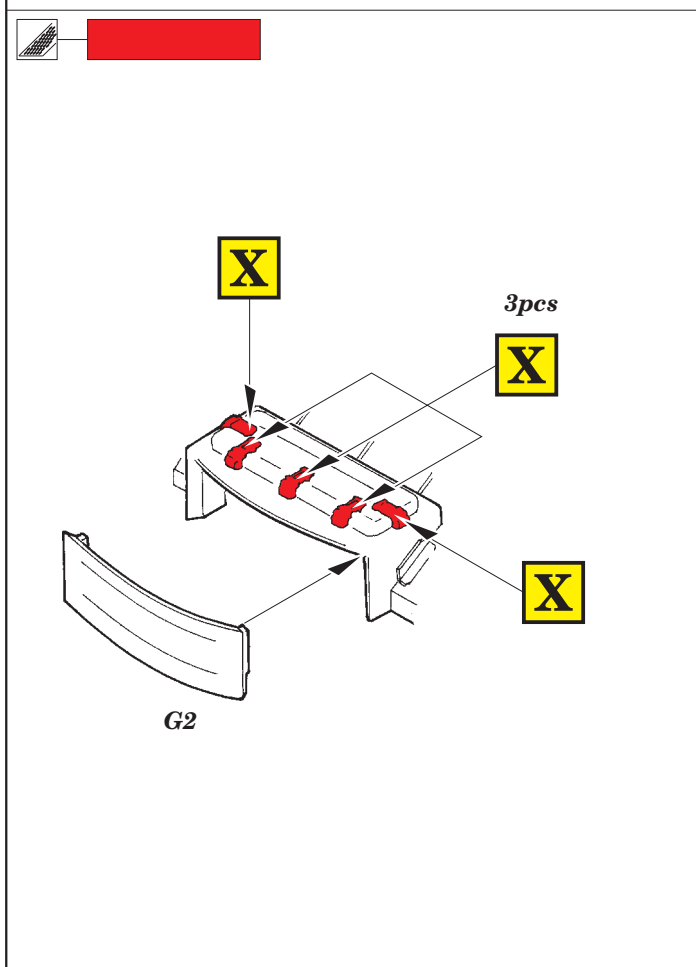
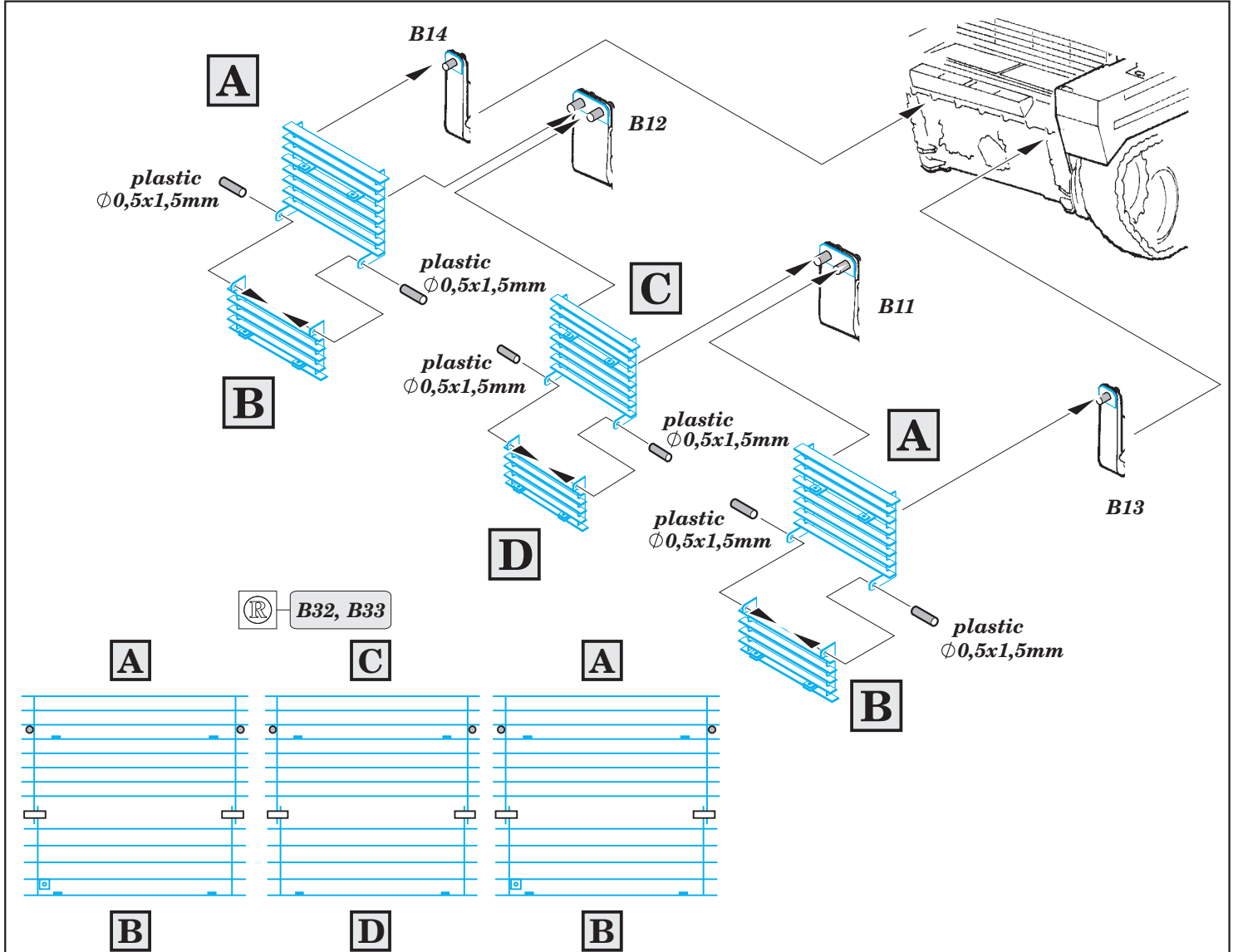

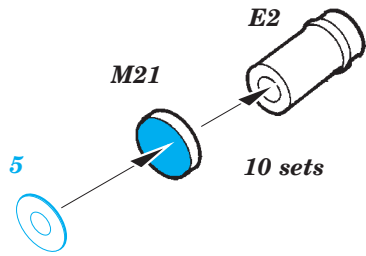
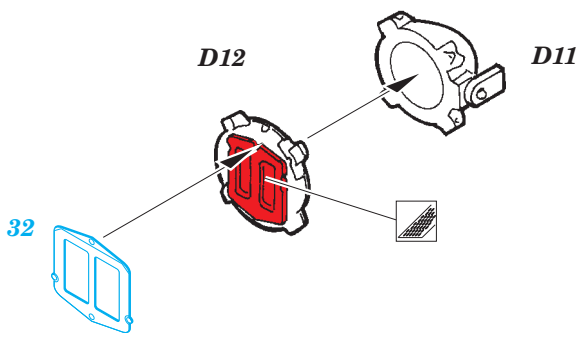
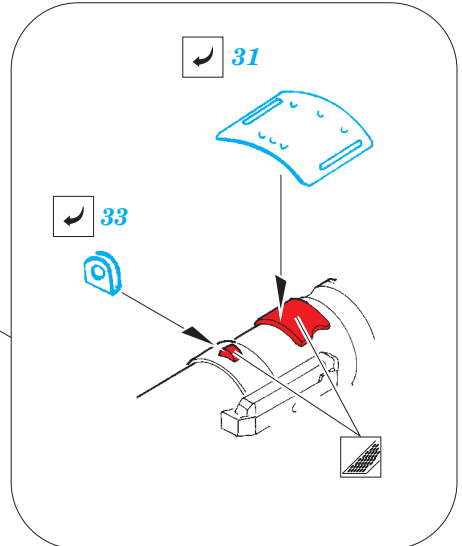
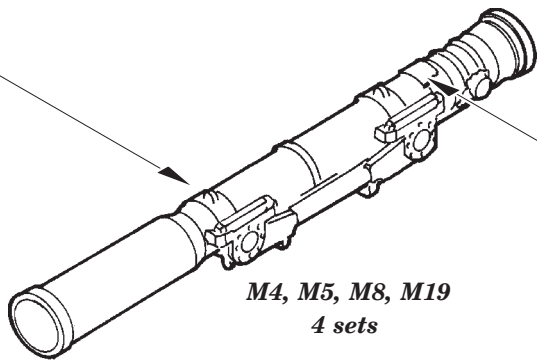
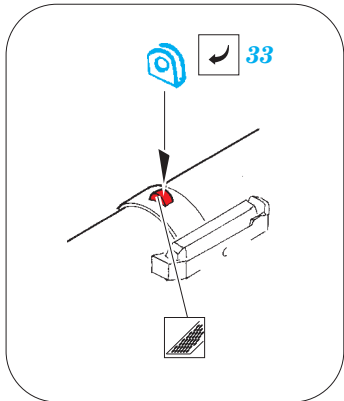
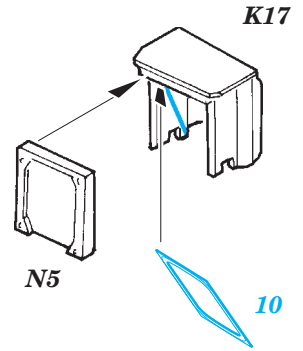
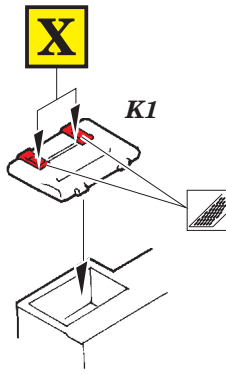
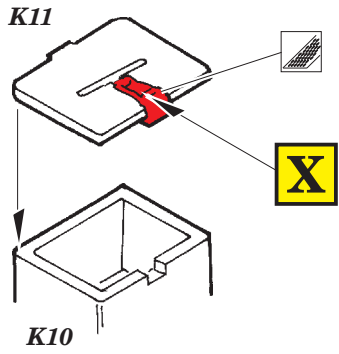

front fender right side

